

F.C. MARCHINI

Document book

0

0 22/09/2023 F. Marchini

+TBD

User data 1

User data 2

01

1-Document book

Drawing	Description	Folder	Folder description	Revision	Date	File user data 1	Created by
01	Cover page			0	22/09/2023		F. Marchini
02	Drawings list			0	15/09/2023		F. Marchini
03	Drawings list			0	29/09/2023		F. Marchini
04	List of the cables			0	14/09/2023		F. Marchini
05	List of the cables			0	28/09/2023		F. Marchini
06	List of the cables			0	28/09/2023		F. Marchini
07	List of the cables			0	29/09/2023		F. Marchini
08	List of the cables			0	29/09/2023		F. Marchini
09	List of the cables			0	30/09/2023		F. Marchini
10	Radar S-band Power	1	Main	0	14/09/2023		F. Marchini
11	Radar S-band GearBox	1	Main	0	15/09/2023		F. Marchini
12	Radar X-band Power	1	Main	0	25/09/2023		F. Marchini
13	Radar X-band GearBox	1	Main	0	25/09/2023		F. Marchini
14	Console - Power	1	Main	0	26/09/2023		F. Marchini
15	Console #1	1	Main	0	22/09/2023		F. Marchini
16	Console #2	1	Main	0	14/09/2023		F. Marchini
17	Console #3	1	Main	0	19/09/2023		F. Marchini
18	ETH Switch MOXA EDS-510E	1	Main	0	15/09/2023		F. Marchini
19	Power Supply 230VAC/24VDC #5	1	Main	0	15/09/2023		F. Marchini
20	Destreamer LAN / Radar Video	1	Main	0	15/09/2023		F. Marchini
21	DPU Console #1 IN/OUT	1	Main	0	28/09/2023		F. Marchini
22	DPU Console #2 IN/OUT	1	Main	0	28/09/2023		F. Marchini
23	DPU Console #3 IN/OUT	1	Main	0	28/09/2023		F. Marchini
24	UPS #4	2	Video-Radar	0	19/09/2023		F. Marchini
25	PS #4	2	Video-Radar	0	27/09/2023		F. Marchini
26	LAN	2	Video-Radar	0	15/09/2023		F. Marchini
27	HPx-346	2	Video-Radar	0	27/09/2023		F. Marchini
28	RADAR SERVER	2	Video-Radar	0	27/09/2023		F. Marchini
29	Patch Box	3	Patch Box & Co	0	15/09/2023		F. Marchini
30	Multi Ch & ModBus	3	Patch Box & Co	0	30/09/2023		F. Marchini
31	Relays #1,#2,#3	3	Patch Box & Co	0	29/09/2023		F. Marchini
32	TB 1-5	3	Patch Box & Co	0	29/09/2023		F. Marchini
33	TB 6-10	3	Patch Box & Co	0	29/09/2023		F. Marchini
34	Cablage 1-5	3	Patch Box & Co	0	29/09/2023		F. Marchini

F.C. MARCHINI

Document book

0

0 15/09/2023 F. Marchini

+TBD

User data 1

User data 2

02

-> 1-Document book

Drawing	Description	Folder	Folder description	Revision	Date	File user data 1	Created by
35	Cablage 6-10	3	Patch Box & Co	0	29/09/2023		F. Marchini
36	Patch Power	3	Patch Box & Co	0	30/09/2023		F. Marchini
37	LT-YRAC1-(1/2)			0	30/09/2023		F. Marchini
38	LT-YRAC1-(2/2)			0	30/09/2023		F. Marchini
39	Aux Control-(1/2)			0	30/09/2023		F. Marchini
40	Aux Control-(2/2)			0	30/09/2023		F. Marchini
41	TB1-(1/2)			0	30/09/2023		F. Marchini
42	TB1-(2/2)			0	30/09/2023		F. Marchini
43	TB2-(1/1)			0	30/09/2023		F. Marchini
44	TB3-(1/1)			0	30/09/2023		F. Marchini
45	TB4-(1/1)			0	30/09/2023		F. Marchini
46	TB5-(1/1)			0	30/09/2023		F. Marchini
47	TB6-(1/1)			0	30/09/2023		F. Marchini
48	TB9-(1/2)			0	30/09/2023		F. Marchini
49	TB9-(2/2)			0	30/09/2023		F. Marchini
50	TB10-(1/1)			0	30/09/2023		F. Marchini

SOLIDWORKS Electrical

F.C. MARCHINI

Document book

				0
0	29/09/2023	F. Marchini		03
User data 1			User data 2	

+TBD

	Mark	Description	Cores	From location	To location	Reference	Manufacturer	Art. number	Length (m)	Cable user data 1	Cable user data 2
1	W1	Power Supply	3	Ship PWR	Radar Nav	PCX 3G 1.50	Nexans	90110201	0		
2	W2	Power Supply	3	Radar Nav	Radar Nav	PCX 3G 1.50	Nexans	90110201	0		
3	W3	Power Supply	3	Radar Nav	Radar Nav	PCX 3G 1.50	Nexans	90110201	0		
4	W4	CAT 6A	8	Radar Nav	Radar Nav	SFP6A 4P 0.55	Prysmian	SC000060	0		
5	W5	Power Supply	3	TBD	Radar Aux	PCX 3G 1.50	Nexans	90110201	0		
6	W6	Power Supply	3	Radar Aux	Radar Aux	PCX 3G 1.50	Nexans	90110201	0		
7	W7	Power Supply	3	Radar Aux	Radar Aux	PCX 3G 1.50	Nexans	90110201	0		
8	W8	Power Supply	3	Ship PWR	Radar Aux	PCX 3G 1.50	Nexans	90110201	0		
9	W9	Power Supply	3	Radar Aux	Radar Aux	PCX 3G 1.50	Nexans	90110201	0		
10	W10	Fiber	6	Cons #1	Intranet Room	FO 6M3 6.00 OM3	Helkama	SC000065	0		
11	W11	Fiber	6	Cons #1	Cons #3	FO 6M3 6.00 OM3	Helkama	SC000065	0		
12	W12	Fiber	6	Cons #2	Cons #3	FO 6M3 6.00 OM3	Helkama	SC000065	0		
13	W13	Fiber	6	Cons #2	Intranet Room	FO 6M3 6.00 OM3	Helkama	SC000065	0		
14	W14	Power Supply	3	Radar Aux	Radar Aux	PCX 3G 1.50	Nexans	90110201	0		
15	W15	Power Supply	3	Radar Nav	Radar Nav	PCX 3G 1.50	Nexans	90110201	0		
16	W16	Coax Cable	2	Video / Lan	Ship PWR	COAL 1RG 11.00	Belden	SA042984	0		
17	W17	Power Supply	3	Radar Nav	Cons #1	PCX 3G 1.50	Nexans	90110201	0		
18	W18	Power Supply	3	Radar Nav	Cons #1	PCX 3G 1.50	Nexans	90110201	0		
19	W19	Power Supply	3	Radar Nav	Cons #1	PCX 3G 1.50	Nexans	90110201	0		
20	W20	CAT 6A	8	Cons #3	Radar Nav	SFP6A 4P 0.55	Prysmian	SC000060	0		
21	W21	Coax Cable	2	Video / Lan	Ship PWR	COAL 1RG 11.00	Belden	SA042984	0		
22	W22	Power Supply	3	Radar Nav	Radar Nav	PCX 3G 1.50	Nexans	90110201	0		
23	W23	Coax Cable	2	Video / Lan	Ship PWR	COAL 1RG 11.00	Belden	SA042984	0		
24	W24	Power Supply	3	Cons #3	Radar Nav	PCX 3G 1.50	Nexans	90110201	0		
25	W25	Power Supply	3	Ship PWR	Radar Nav	PCX 3G 1.50	Nexans	90110201	0		
26	W26	Power Supply	3	Cons #3	Radar Nav	PCX 3G 1.50	Nexans	90110201	0		
27	W27	DIV	6	Cons #1	Radar Nav	TX 3P 0.75	Nexans	90401103	0		
28	W28	DIV	6	Radar Nav	Cons #3	TX 3P 0.75	Nexans	90401103	0		
29	W29	Power Supply	3	Radar Aux	Room Patch	PCX 3G 1.50	Nexans	90110201	0		
30	W30	Power Supply	3	Radar Nav	Radar Nav	PCX 3G 1.50	Nexans	90110201	0		
31	W31	CAT 6A	8	Radar Nav	Cons #1	SFP6A 4P 0.55	Prysmian	SC000060	0		
32	W32	CAT 6A	8	Radar Nav	Intranet Room	SFP6A 4P 0.55	Prysmian	SC000060	0		
33	W33	DIV	6	Radar Nav	Cons #1	TX 3P 0.75	Nexans	90401103	0		

F.C. MARCHINI

Document book

0

0 14/09/2023 F. Marchini

+TBD

User data 1

User data 2

04

	Mark	Description	Cores	From location	To location	Reference	Manufacturer	Art. number	Length (m)	Cable user data 1	Cable user data 2
67	W67	Power Supply	3	Cons #2	Cons #2	PCX 3G 1.50	Nexans	90110201	0		
68	W68	Power Supply	3	Cons #2	Cons #2	PCX 3G 1.50	Nexans	90110201	0		
69	W69	DIV	6	Cons #3	Radar Nav	TX 3P 0.75	Nexans	90401103	0		
70	W70	CAT 6A	8	Cons #3	Cons #3	SFP6A 4P 0.55	Prysmian	SC000060	0		
71	W71	Power Supply	3	Cons #3	Cons #3	PCX 3G 1.50	Nexans	90110201	0		
72	W72	Power Supply	3	Cons #3	CTS	PCX 3G 1.50	Nexans	90110201	0		
73	W73	Power Supply	3	Video / Lan	Cons #3	PCX 3G 1.50	Nexans	90110201	0		
74	W74	Power Supply	3	Video / Lan	Cons #3	PCX 3G 1.50	Nexans	90110201	0		
75	W75	Power Supply	3	Video / Lan	Cons #3	PCX 3G 1.50	Nexans	90110201	0		
76	W76	Power Supply	3	Video / Lan	Cons #3	PCX 3G 1.50	Nexans	90110201	0		
77	W77	Power Supply	3	Cons #3	Cons #3	PCX 3G 1.50	Nexans	90110201	0		
78	W78	Power Supply	3	Cons #3	Cons #3	PCX 3G 1.50	Nexans	90110201	0		
79	W79	CAT 6A	8	Cons #3	Cons #3	SFP6A 4P 0.55	Prysmian	SC000060	0		
80	W80	Power Supply	3	TB	TBD	PCX 3G 1.50	Nexans	90110201	0	TH6.W4	
81	W81	CAT 6A	8	Cons #3	CTS	SFP6A 4P 0.55	Prysmian	SC000060	0		
82	W82	DIV	6	CTS	Cons #3	TX 3P 0.75	Nexans	90401103	0		
83	W83	DIV	6	Cons #3	Ship PWR	TX 3P 0.75	Nexans	90401103	0	A7 00035	ND 600001
84	W84	DIV	6	Cons #3	Ship PWR	TX 3P 0.75	Nexans	90401103	0	DD600013	
85	W85	DIV	6	Cons #3	Ship PWR	TX 3P 0.75	Nexans	90401103	0	DD600014	
86	W86	DIV	6	Cons #3	Ship PWR	TX 3P 0.75	Nexans	90401103	0		
87	W87	CAT 6A	8	Room Radar	Radar Nav	SFP6A 4P 0.55	Prysmian	SC000060	0		
88	W88	Power Supply	3	Room Radar	Radar Nav	PCX 3G 1.50	Nexans	90110201	0		
89	W89	Power Supply	3	Room Radar	Radar Nav	PCX 3G 1.50	Nexans	90110201	0		
90	W90	Power Supply	3	Ship PWR	Radar Nav	PCX 3G 1.50	Nexans	90110201	0		
91	W91	Power Supply	3	Room Patch	Room Patch	PCX 3G 1.50	Nexans	90110201	0		
92	W92	Fiber	6	Intranet Room	Room Patch	FO 6M3 6.00 OM3	Helkama	SC000065	0		
93	W93	Fiber	6	Intranet Room	Room Patch	FO 6M3 6.00 OM3	Helkama	SC000065	0		
94	W94	CAT 6A	8	Video / Lan	Intranet Room	SFP6A 4P 0.55	Prysmian	SC000060	0		
95	W95	CAT 6A	8	Video / Lan	Intranet Room	SFP6A 4P 0.55	Prysmian	SC000060	0		
96	W96	Power Supply	3	Room Radar	Intranet Room	PCX 3G 1.50	Nexans	90110201	0		
97	W97	CAT 6A	8	Video / Lan	Intranet Room	SFP6A 4P 0.55	Prysmian	SC000060	0		
98	W98	CAT 6A	8	Video / Lan	Intranet Room	SFP6A 4P 0.55	Prysmian	SC000060	0		
99	W99	Power Supply	3	Room Radar	Intranet Room	PCX 3G 1.50	Nexans	90110201	0		

F.C. MARCHINI

Document book

0

0 28/09/2023 F. Marchini

+TBD

User data 1

User data 2

06

	Mark	Description	Cores	From location	To location	Reference	Manufacturer	Art. number	Length (m)	Cable user data 1	Cable user data 2
13...	W133		2	TB	TB	TX 1P 0.75	Nexans	90401101	0	TH6.W27	
13...	W134		2	Ship PWR	TB	TX 1P 0.75	Nexans	90401101	0	TH6.W29	
13...	W135		2	Patch Box	Patch Box	TX 1P 0.75	Nexans	90401101	0	TH6.W22	
13...	W136		2	Patch Box	TB	TX 1P 0.75	Nexans	90401101	0	TH6.W21	
13...	W137	Power Supply	3	TB	TBD	PCX 3G 1.50	Nexans	90110201	0		
13...	W138	Power Supply	3	Patch Box	TBD	PCX 3G 1.50	Nexans	90110201	0	TH6.W20	
13...	W139	Power Supply	3	TBD	TB	PCX 3G 1.50	Nexans	90110201	0		
14...	W140		2	Patch Box	TB	TX 1P 0.75	Nexans	90401101	0		
14...	W141		24	TB	Patch Box	CANB(S)-RH 24X0....	Prysmian		0	TH6.W1	
14...	W142		24	Patch Box	Patch Box	CANB(S)-RH 24X0....	Prysmian		0	TH6.W7	Déport vidéo Coffre...
14...	W143	CAT 6A	8	Cons #3	Patch Box	SFP6A 4P 0.55	Prysmian	SC000060	0	TH6.00001	
14...	W144	CAT 6A	8	Patch Box	Patch Box	SFP6A 4P 0.55	Prysmian	SC000060	0	TH6.W8	
14...	W145	Power Supply	3	TB	Patch Box	PCX 3G 1.50	Nexans	90110201	0	TH6.W2	
14...	W146		24	TB	Patch Box	CANB(S)-RH 24X0....	Prysmian		0	TH6.W3	
14...	W147	Power Supply	3	TB	Patch Box	PCX 3G 1.50	Nexans	90110201	0	TH6.W4	
14...	W148	Power Supply	3	TB	Patch Box	PCX 3G 1.50	Nexans	90110201	0	TH6.W5	
14...	W149	Power Supply	3	TB	Patch Box	PCX 3G 1.50	Nexans	90110201	0	TH6.W6	
15...	W150		24	TB	Patch Box	CANB(S)-RH 24X0....	Prysmian		0	TH6.W9	
15...	W151	DIV	6	Patch Box	TB	TX 3P 0.75	Nexans	90401103	0	TH6.W10	COM1 MOXA
15...	W152		2	Patch Box	TB	TX 1P 0.75	Nexans	90401101	0		
15...	W153		24	Patch Box	TBD	CANB(S)-RH 24X0....	Prysmian		0	AC6.00007	
15...	W154	Power Supply	3	Patch Box	TBD	PCX 3G 1.50	Nexans	90110201	0	AC6.00012	
15...	W155		24	Patch Box	TBD	CANB(S)-RH 24X0....	Prysmian		0	NT6.00006	
15...	W156	Power Supply	3	Patch Box	TBD	PCX 3G 1.50	Nexans	90110201	0	A7 0012 (DD6.000...	
15...	W157	Power Supply	3	Patch Box	TBD	PCX 3G 1.50	Nexans	90110201	0	AC6.00013	
15...	W158		2	Patch Box	TB	TX 1P 0.75	Nexans	90401101	0		
15...	W159	CAT 6A	8	TBD	TBD	SFP6A 4P 0.55	Prysmian	SC000060	0	SIERRA-2000-037	
16...	W160		24	TBD	TBD	CANB(S)-RH 24X0....	Prysmian		0	AC6.00014	
16...	W161		24	Patch Box	TBD	CANB(S)-RH 24X0....	Prysmian		0	TH6.00002	
16...	W162		24	Patch Box	TBD	CANB(S)-RH 24X0....	Prysmian		0		
16...	W163		2	Patch Box	TB	TX 1P 0.75	Nexans	90401101	0		
16...	W164	CAT 6A	8	Patch Box	TBD	SFP6A 4P 0.55	Prysmian	SC000060	0	TH6.W25	USB Male to Male
16...	W165	Power Supply	3	TBD	TB	PCX 3G 1.50	Nexans	90110201	0	TH6.W30	

F.C. MARCHINI

Document book

0

0 29/09/2023 F. Marchini

User data 1

User data 2

08

+TBD

	Mark	Description	Cores	From location	To location	Reference	Manufacturer	Art. number	Length (m)	Cable user data 1	Cable user data 2
16...	W166	Power Supply	3	TBD	TBD	PCX 3G 1.50	Nexans	90110201	0	TH6.W32	
16...	W167	Power Supply	3	TB	TBD	PCX 3G 1.50	Nexans	90110201	0	TH6.W33	
16...	W168	Power Supply	3	TB	TBD	PCX 3G 1.50	Nexans	90110201	0	TH6.W37	
16...	W169	Power Supply	3	Patch Box	TB	PCX 3G 1.50	Nexans	90110201	0	TH6.W5	
17...	W170	Power Supply	3	TBD	TBD	PCX 3G 1.50	Nexans	90110201	0	TH6.W31	
17...	W171	CAT 6A	8	Patch Box	TBD	SFP6A 4P 0.55	Prysmian	SC000060	0		
17...	W172	Power Supply	3	TBD	TB	PCX 3G 1.50	Nexans	90110201	0		
17...	W173		2	TBD	TB	TX 1P 0.75	Nexans	90401101	0		
17...	W174	DIV	6	TBD	TB	TX 3P 0.75	Nexans	90401103	0		
17...	W175	DIV	6	TBD	TB	TX 3P 0.75	Nexans	90401103	0		
17...	W176	DIV	6	TBD	TB	TX 3P 0.75	Nexans	90401103	0		
17...	W177	DIV	6	TBD	TB	TX 3P 0.75	Nexans	90401103	0		
17...	W178	Power Supply	3	TBD	TB	PCX 3G 1.50	Nexans	90110201	0		
17...	W179		2			AFUMEX 1000 FR-N...	Prysmian		0		

F.C. MARCHINI

Document book

											0
0	30/09/2023	F. Marchini									09
User data 1									User data 2		

+TBD

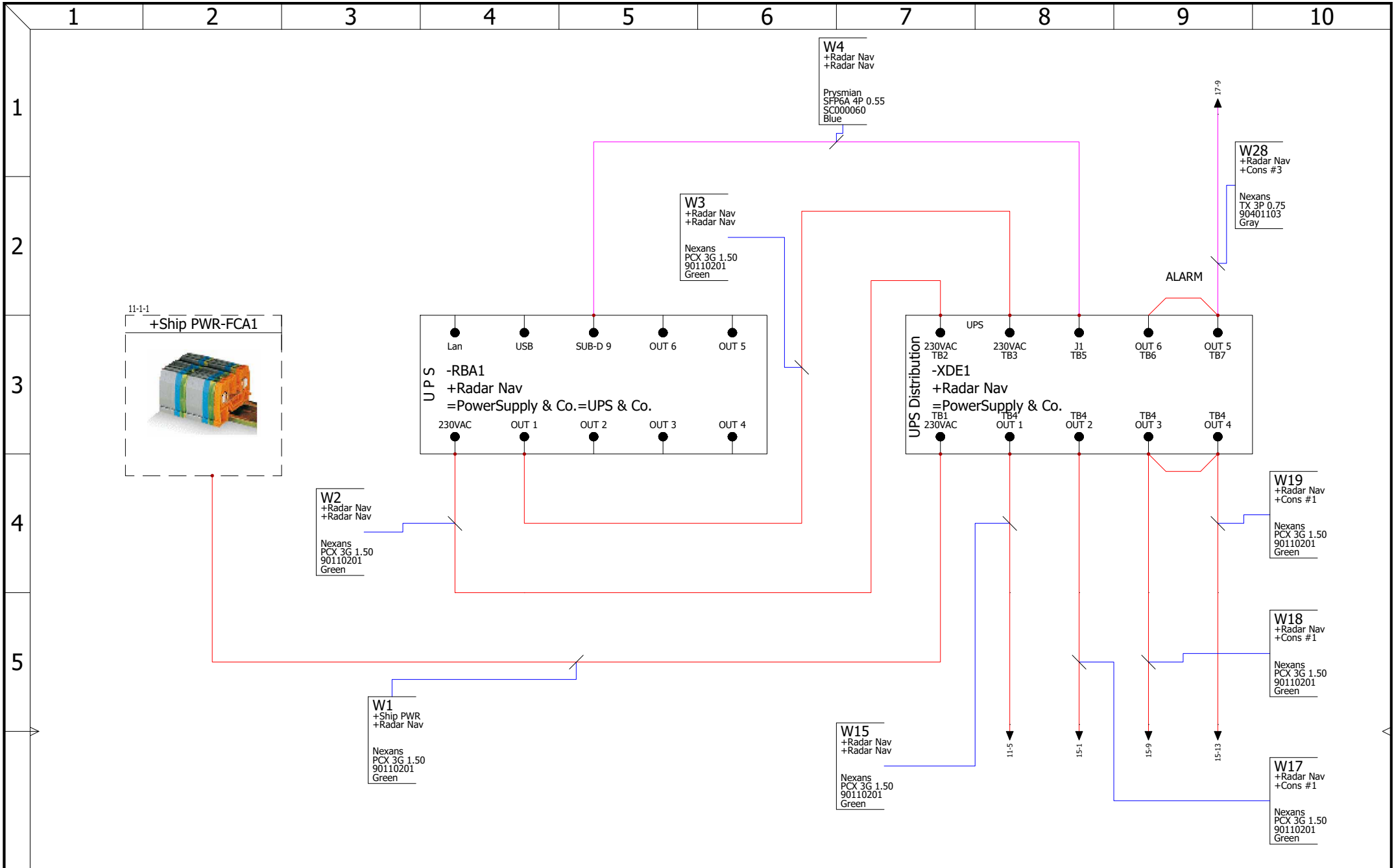

F.C. MARCHINI

Radar S-band Power

CONTRACT:

LOCATION: +TBD

				REVISION
				0
0	14/09/2023	F. Marchini		
REV.	DATE	NAME	CHANGES	
User data 1			User data 2	
				SCHEME
				10

1 2 3 4 5 6 7 8 9 10

1

2

3

4

5

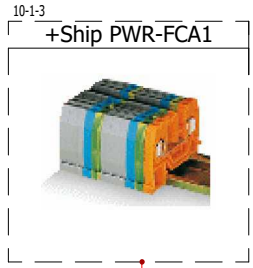

W22
+Radar Nav
+Radar Nav

Nexans
PCX 3G 1.50
90110201
Green

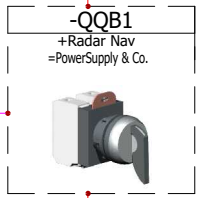

W30
+Radar Nav
+Radar Nav

Nexans
PCX 3G 1.50
90110201
Green

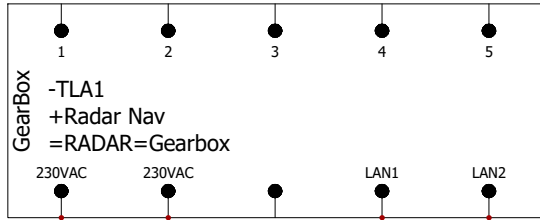

W31
+Radar Nav
+Cons #1

Prysmian
SFP6A 4P 0.55
SC000060
Blue

W32
+Radar Nav
+Intranet Room

Prysmian
SFP6A 4P 0.55
SC000060
Blue

W33
+Radar Nav
+Cons #1

Nexans
TX 3P 0.75
90401103
Gray

W15
+Radar Nav
+Radar Nav

Nexans
PCX 3G 1.50
90110201
Green

15-9

10-8

15-6

18-6

F.C. MARCHINI

Radar S-band GearBox

				REVISION
				0
0	15/09/2023	F. Marchini		
REV.	DATE	NAME	CHANGES	SCHEME
User data 1			User data 2	11

CONTRACT:

LOCATION: +TBD

SOLIDWORKS Electrical

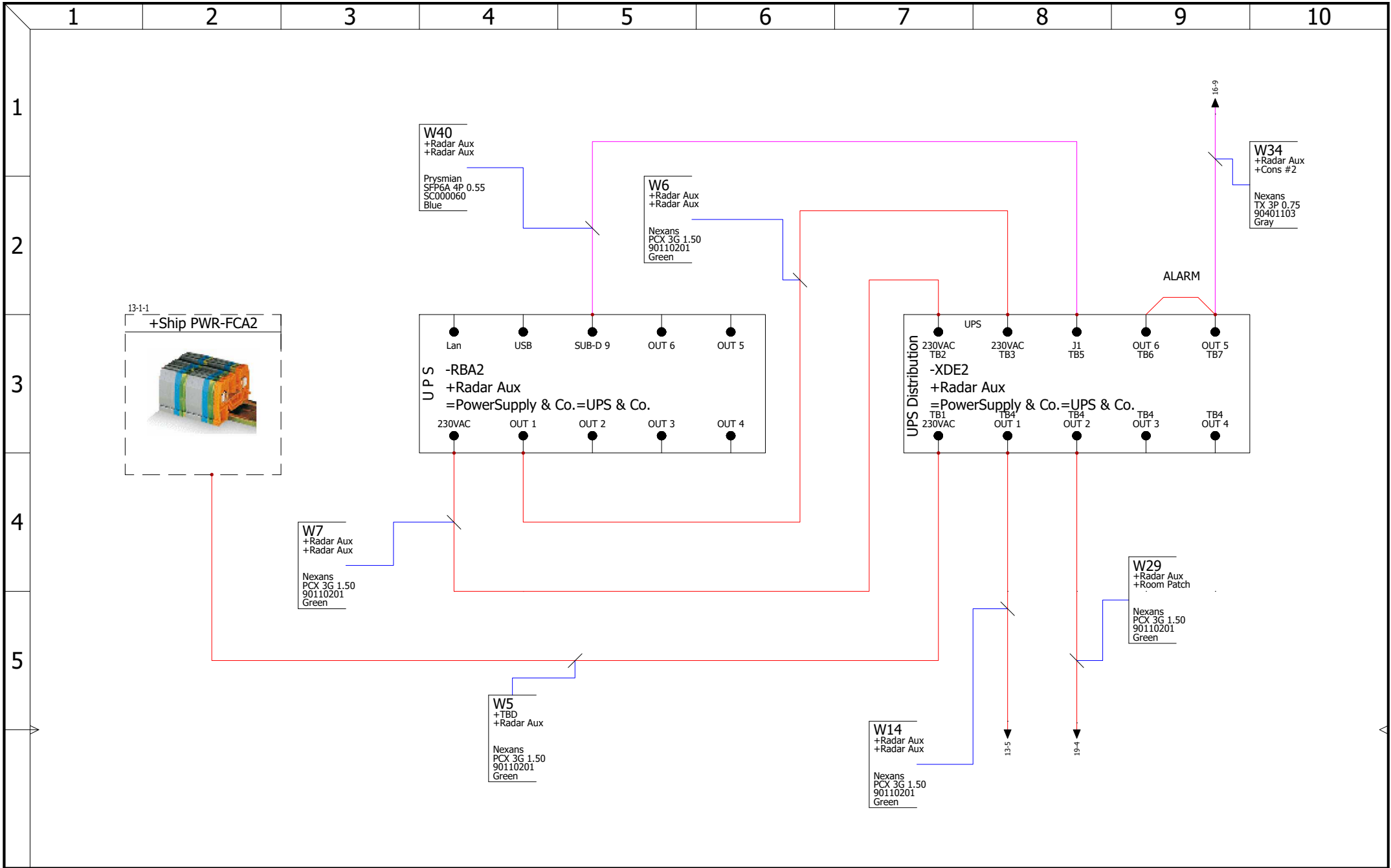

F.C. MARCHINI

Radar X-band Power

				REVISION
				0
0	25/09/2023	F. Marchini		
REV.	DATE	NAME	CHANGES	SCHEME
				12
User data 1			User data 2	

CONTRACT:

LOCATION: +TBD

SOLIDWORKS Electrical

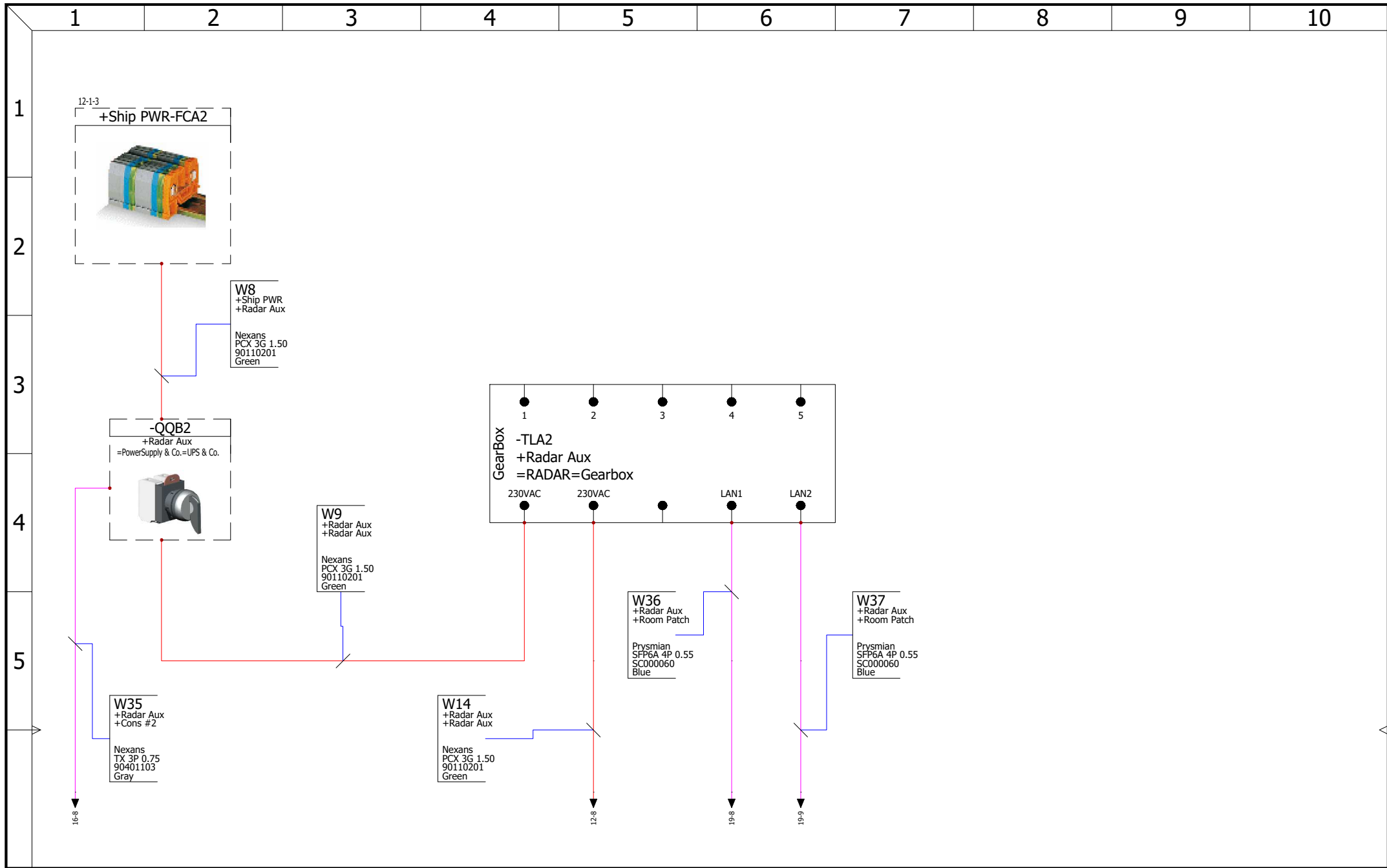

F.C. MARCHINI

Radar X-band GearBox

CONTRACT:		LOCATION: +TBD		REVISION	
				0	
REV.	DATE	NAME	CHANGES		
0	25/09/2023	F. Marchini			
User data 1			User data 2		
					SCHEME
					13

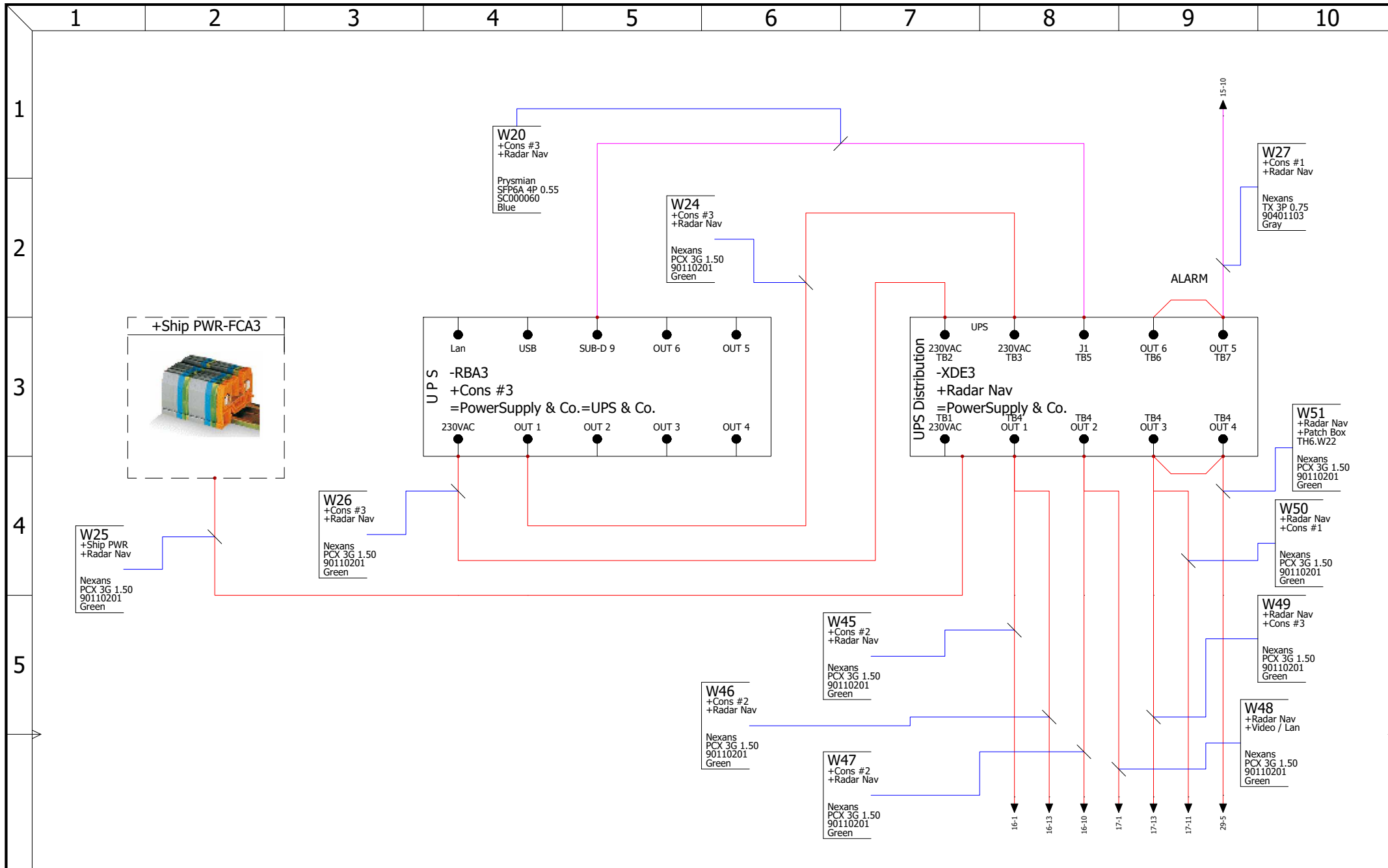

F.C. MARCHINI

Console - Power

CONTRACT:

LOCATION: +TBD

			REVISION
			0
0	26/09/2023	F. Marchini	
REV.	DATE	NAME	CHANGES
User data 1		User data 2	
			SCHEME
			14

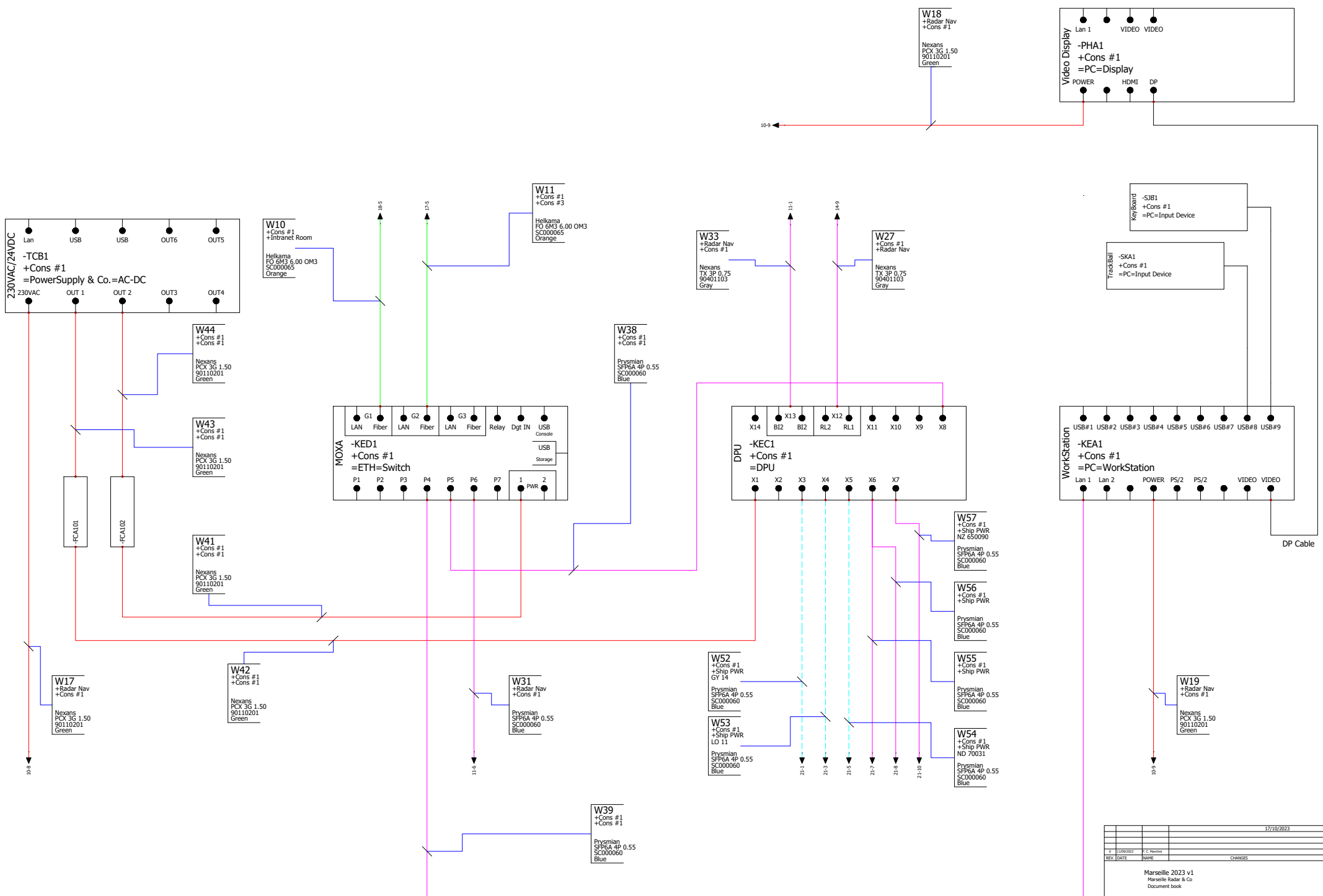

		17/10/2023	
0	11/09/2023	C. C. Heston	
REV.	DATE	NAME	CHANGES
Marseille 2023 v1 Marseille Radar & Co Document book			
		Console #1 +TBD	REVISION 0
		CONTRACT : User data 1	DRAWING 15
		User data 2	

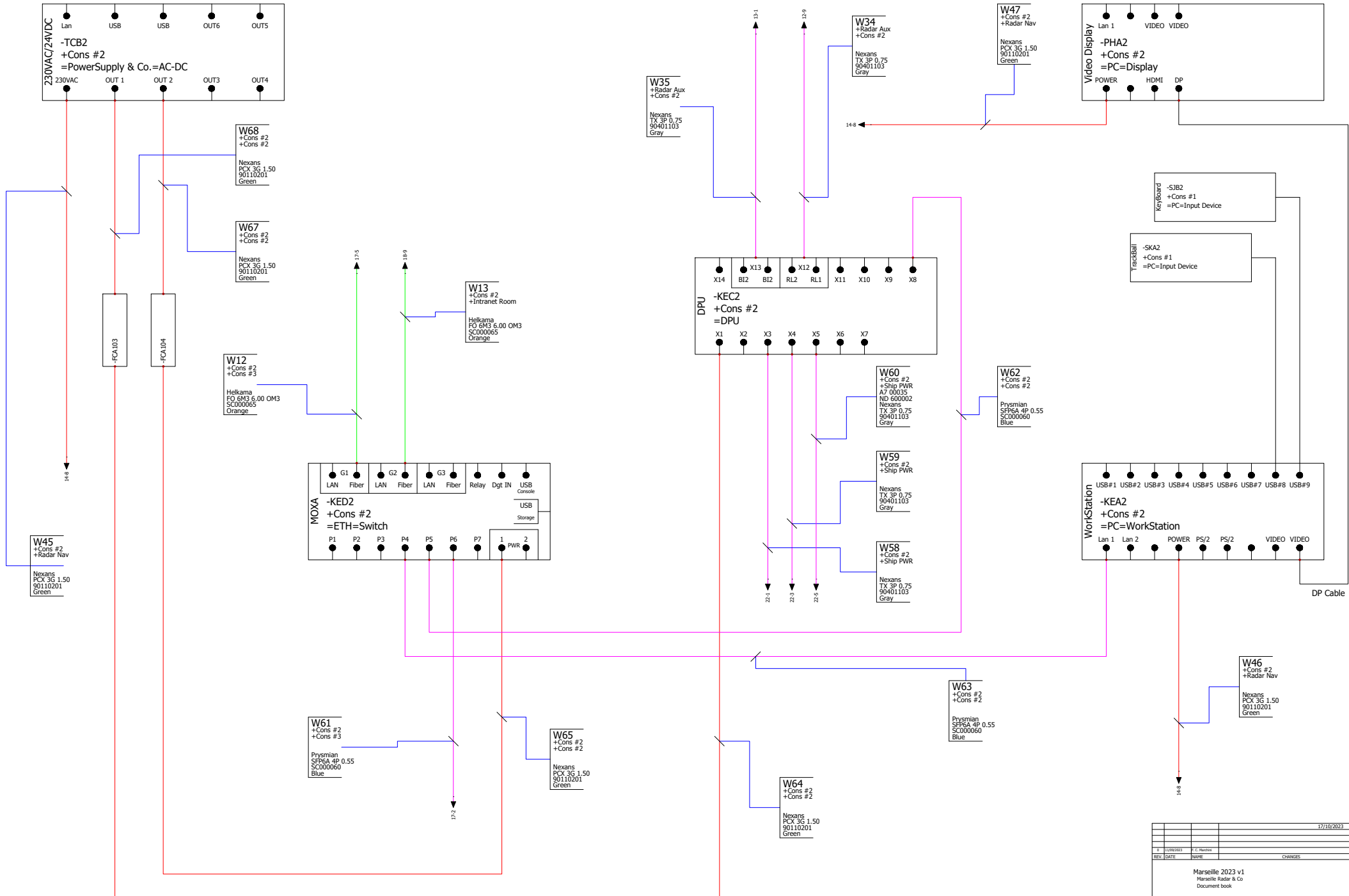

		17/10/2023	
0	15/09/2023	C. E. Heston	
REV.	DATE	NAME	CHANGES
Marseille 2023 v1			
Marseille Radar & Co Document book			
		Console #2	REVISION
		+TBD	0
CONTRACT :		User data 1	DRAWING :
		User data 2	16

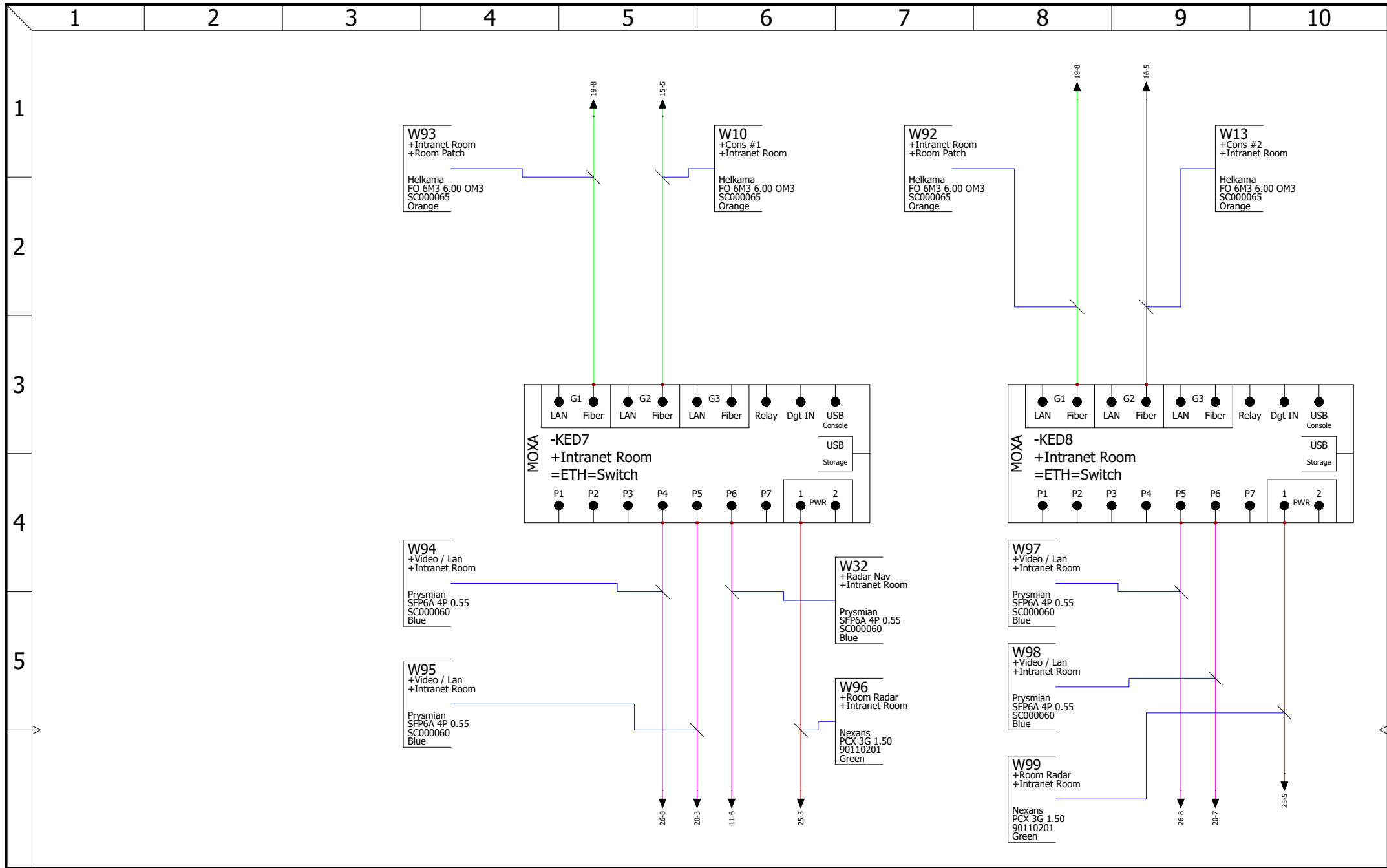

F.C. MARCHINI

ETH Switch MOXA EDS-510E

REVISION

0

0 15/09/2023 F. Marchini

REV. DATE NAME CHANGES

SCHEME

User data 1

User data 2

18

CONTRACT:

LOCATION: +TBD

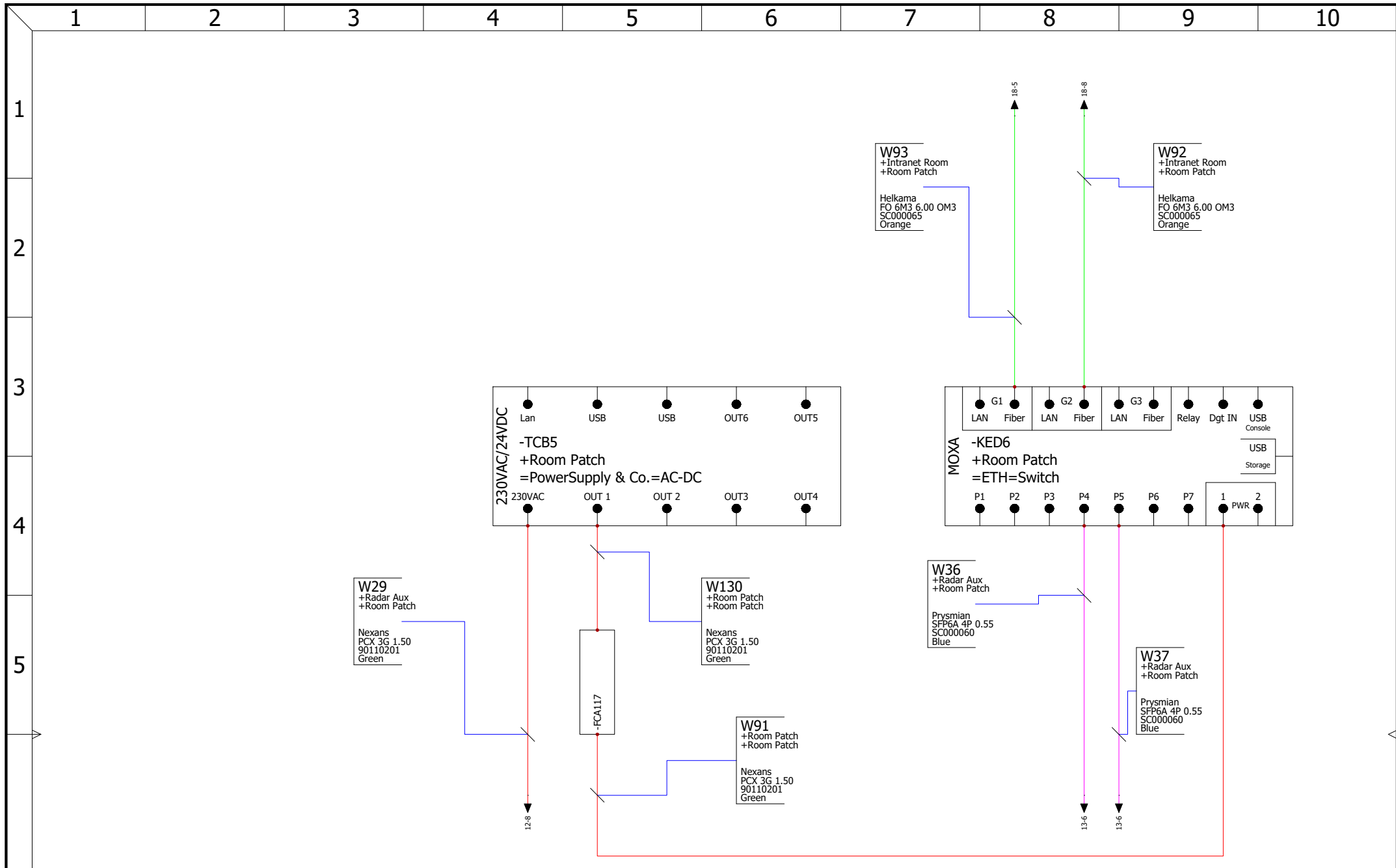

F.C. MARCHINI

Power Supply 230VAC/24VDC #5

CONTRACT:

LOCATION: +TBD

				REVISION
0	15/09/2023	F. Marchini		0
REV.	DATE	NAME	CHANGES	SCHEME
User data 1			User data 2	19

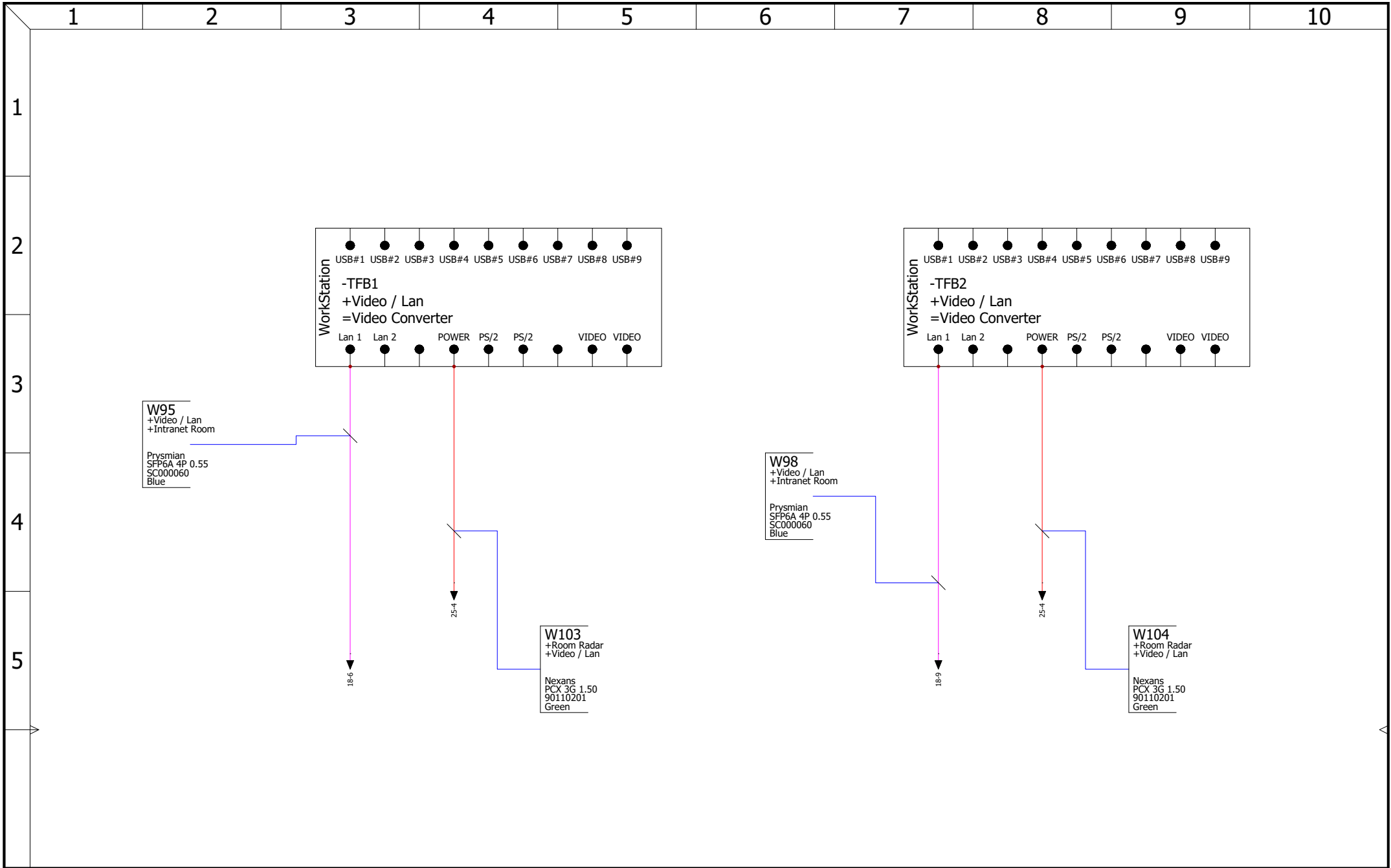

F.C. MARCHINI		Destreamer LAN / Radar Video			REVISION
					0
REV.	DATE	NAME	CHANGES		SCHEME
CONTRACT:		LOCATION: +TBD			20
User data 1				User data 2	

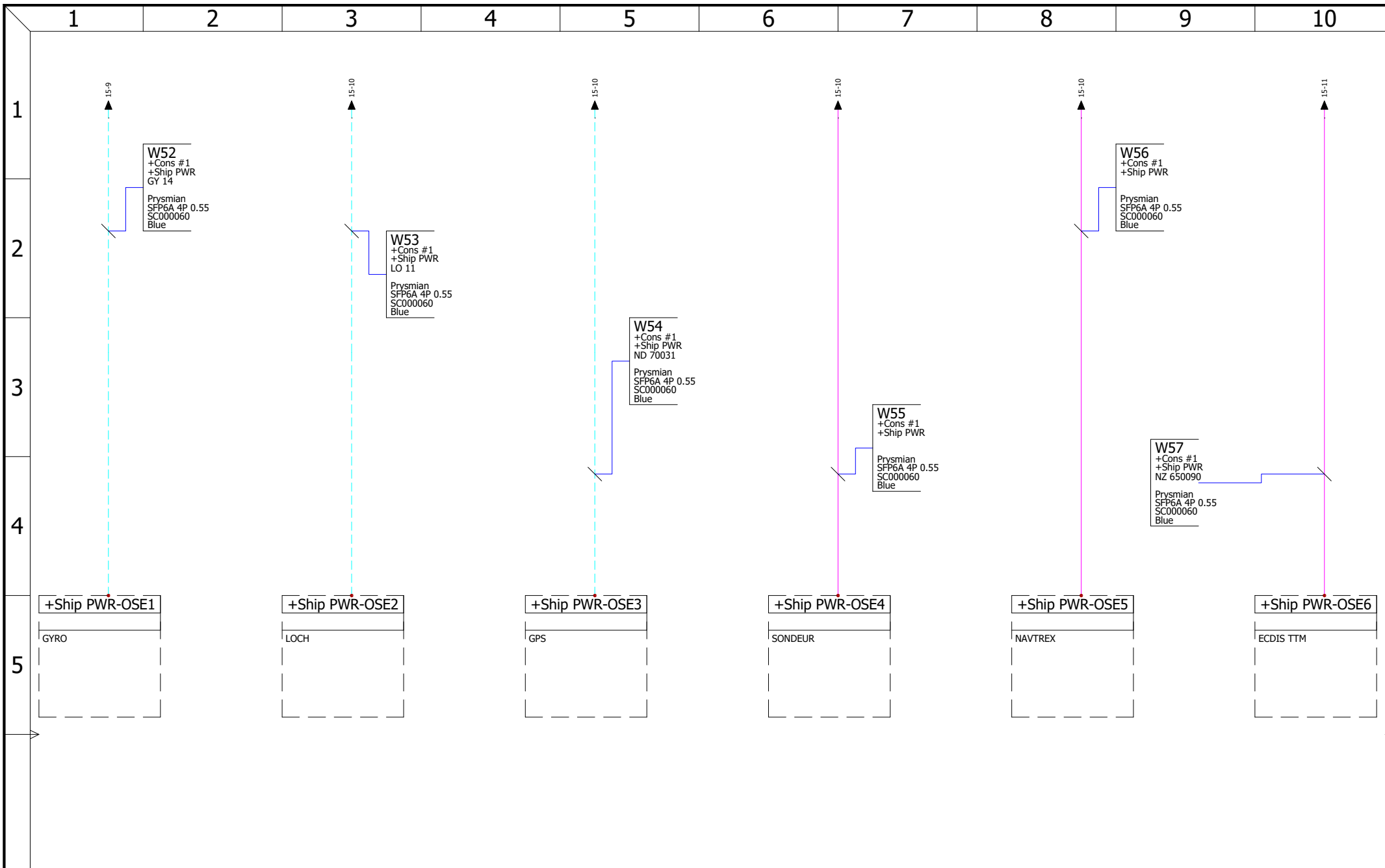

F.C. MARCHINI

DPU Console #1 IN/OUT

CONTRACT:

LOCATION: +TBD

				REVISION
				0
0	28/09/2023	F. Marchini		
REV.	DATE	NAME	CHANGES	SCHEME
User data 1			User data 2	21

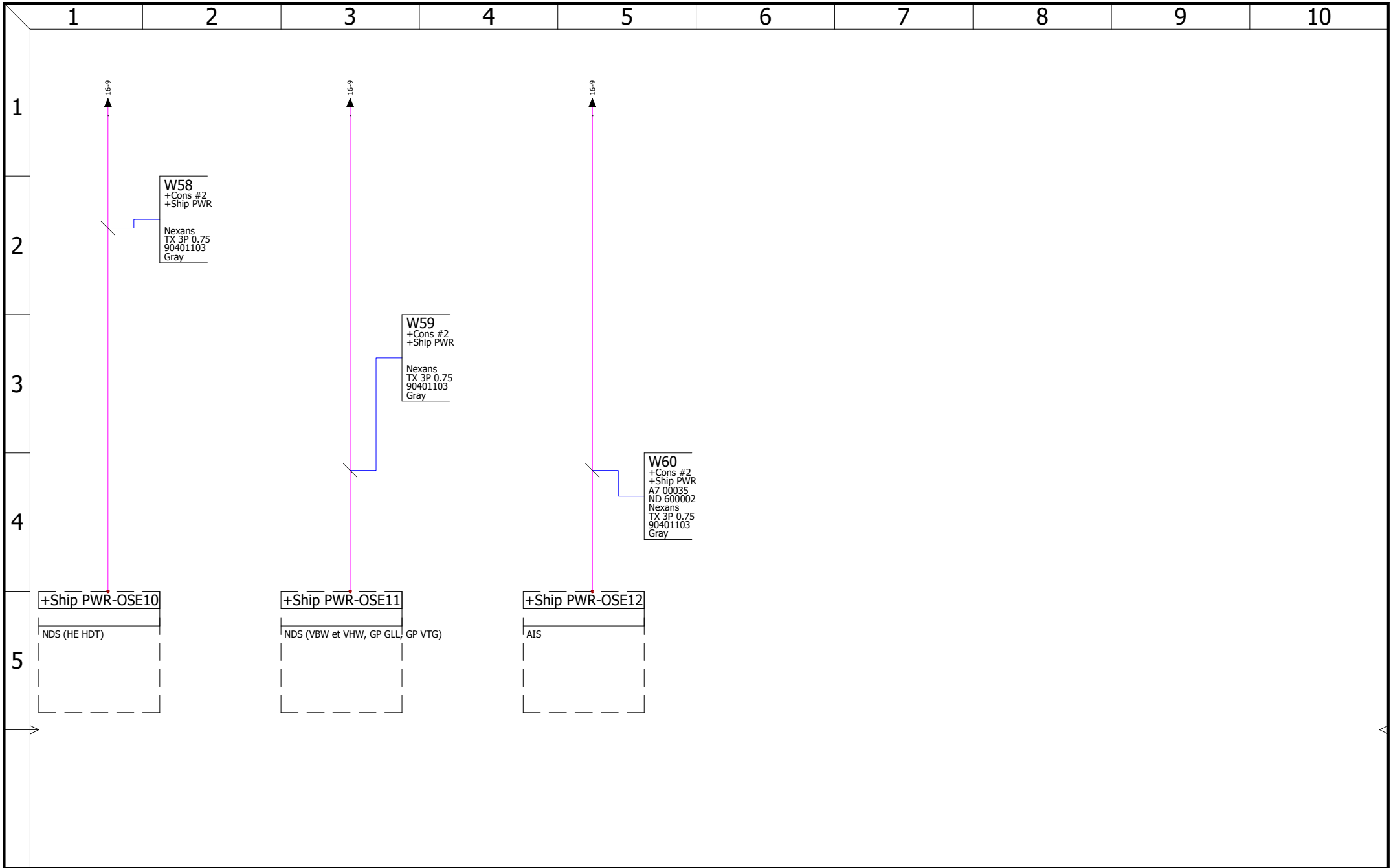

F.C. MARCHINI		DPU Console #2 IN/OUT			REVISION
					0
REV.	DATE	NAME	CHANGES		SCHEME
CONTRACT:		LOCATION: +TBD			22
User data 1				User data 2	

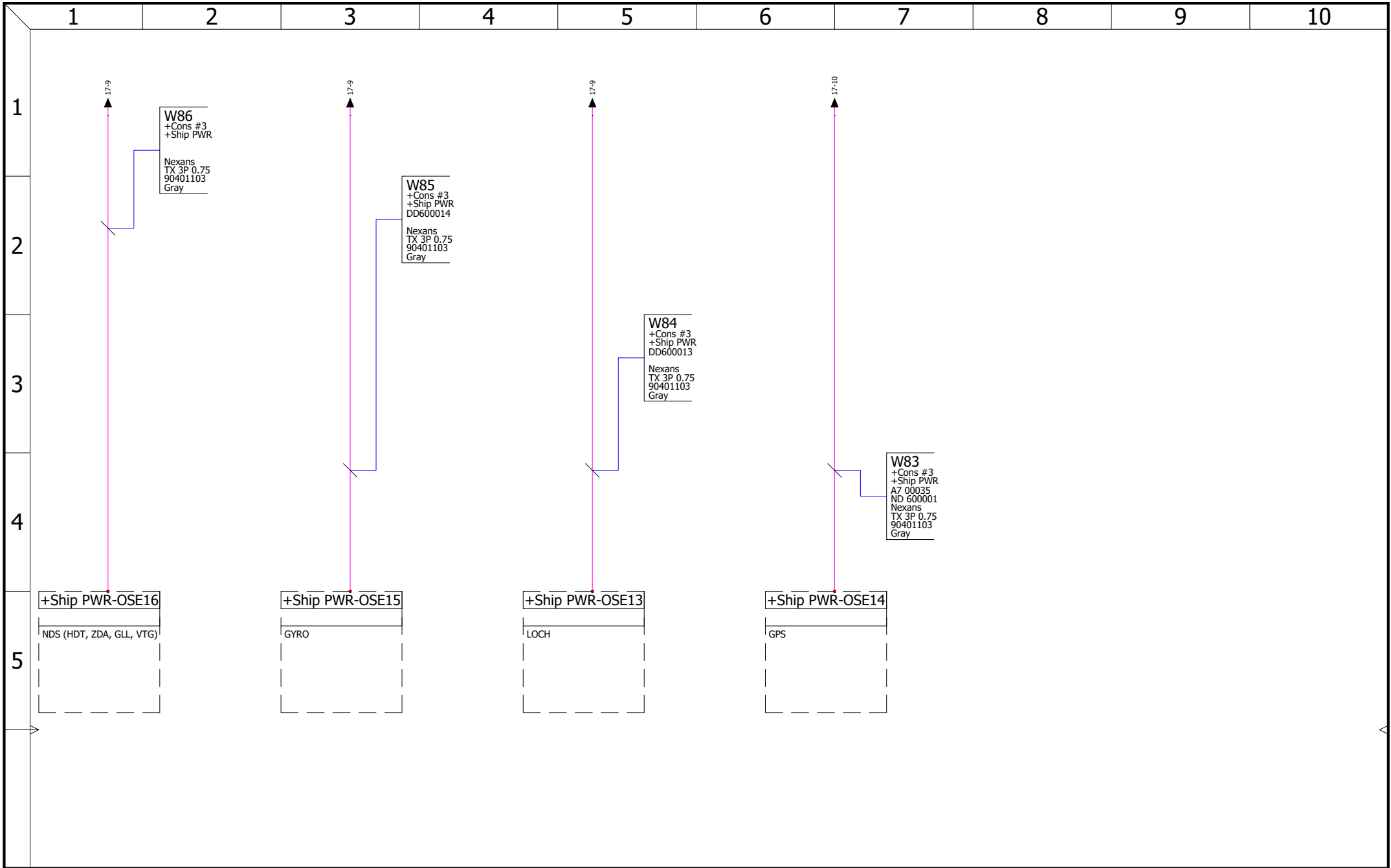

F.C. MARCHINI

DPU Console #3 IN/OUT

				REVISION
				0
0	28/09/2023	F. Marchini		
REV.	DATE	NAME	CHANGES	SCHEME
User data 1			User data 2	23

CONTRACT:

LOCATION: +TBD

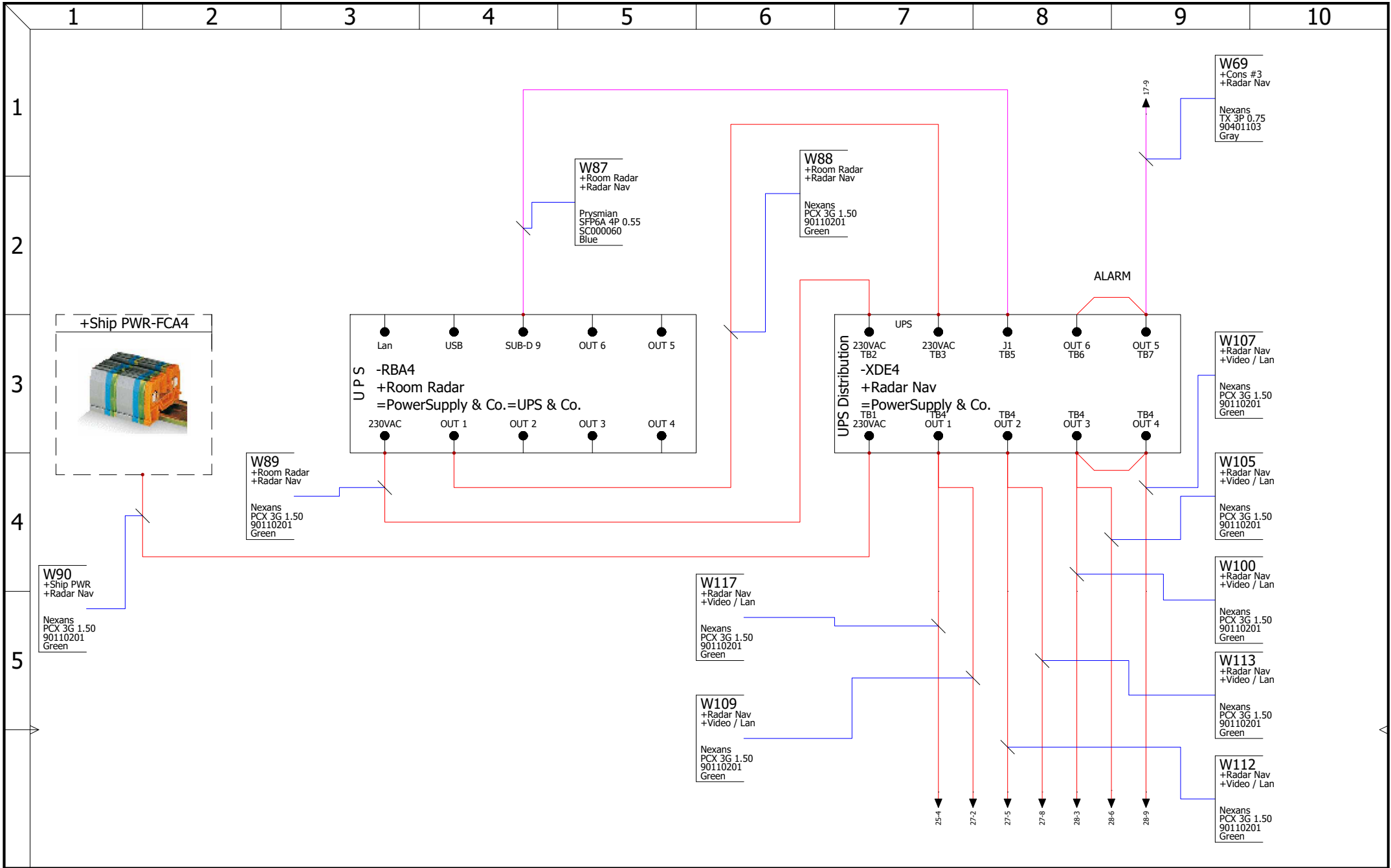

F.C. MARCHINI		UPS #4			REVISION
					0
		0	19/09/2023	F. Marchini	
		REV.	DATE	NAME	CHANGES
CONTRACT:		User data 1			User data 2
LOCATION: +TBD					SCHEME
					24

SOLIDWORKS Electrical

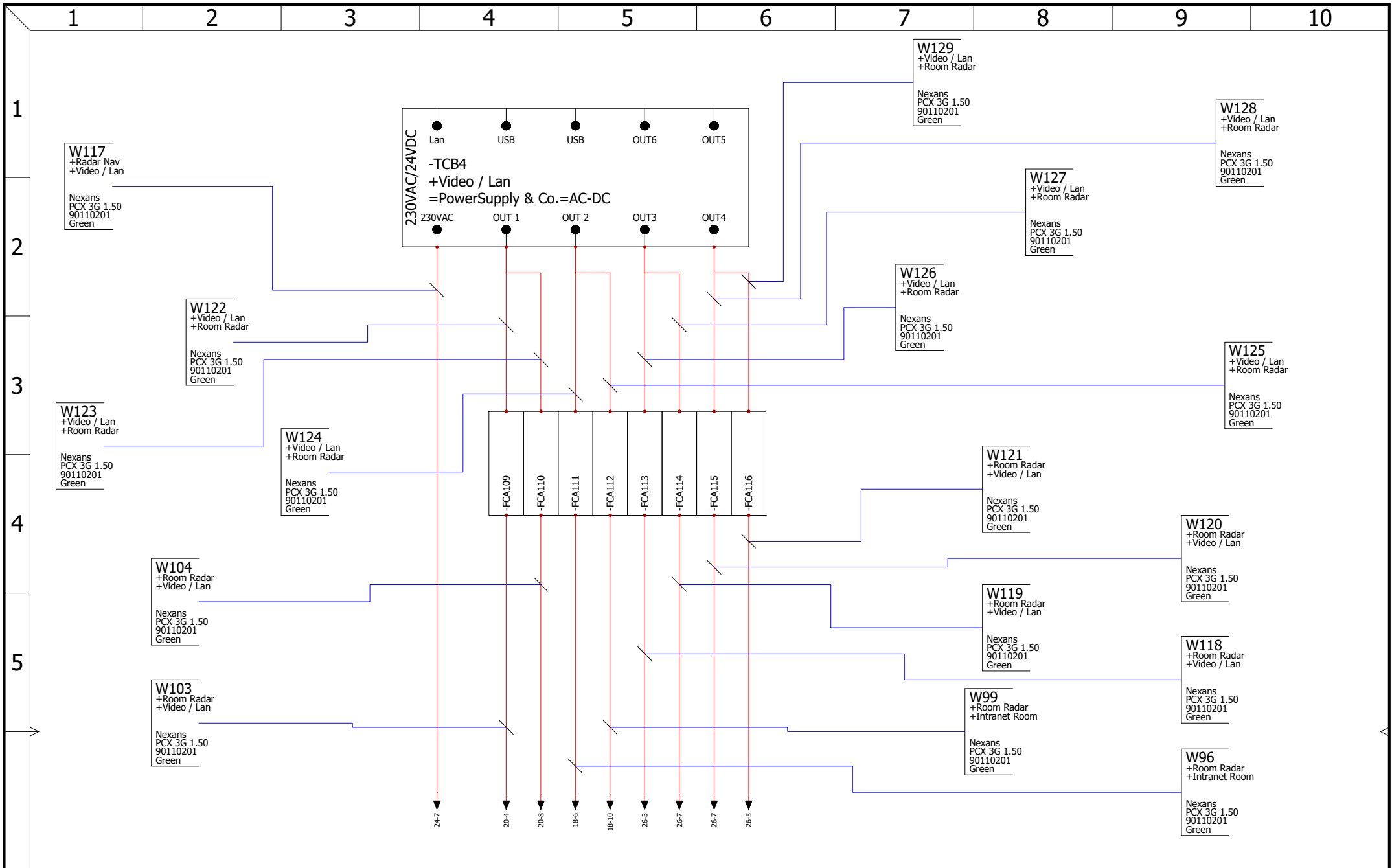

F.C. MARCHINI

PS #4

CONTRACT:		LOCATION: +TBD		REV. DATE NAME		CHANGES		REVISION	
				0 27/09/2023 F. Marchini				0	
				User data 1		User data 2		SCHEME	
								25	

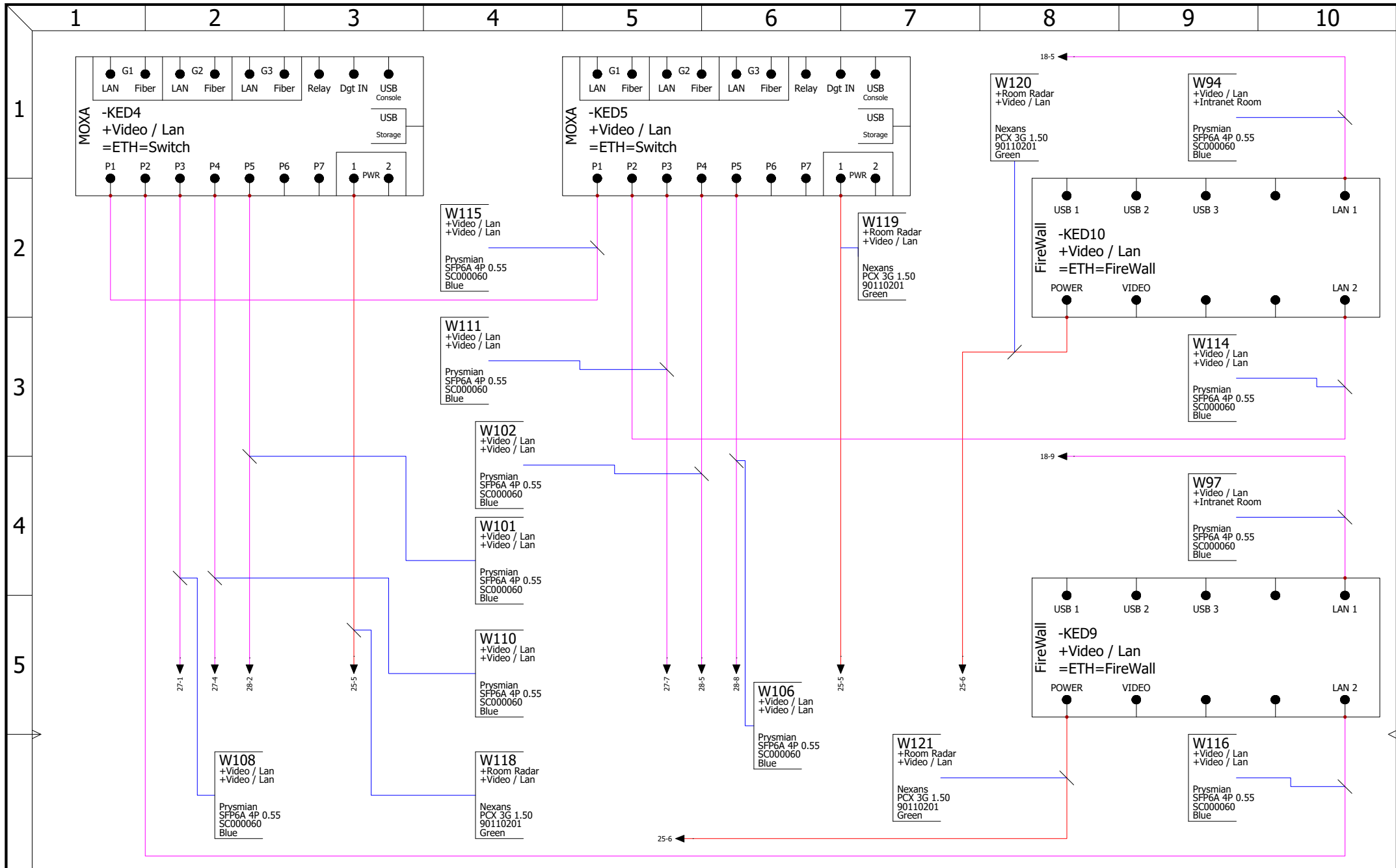

F.C. MARCHINI

LAN

CONTRACT:	LOCATION: +TBD				REVISION
					0
		0	15/09/2023	F. Marchini	
		REV.	DATE	NAME	CHANGES
		User data 1	User data 2	SCHEME	
				26	

SOLIDWORKS Electrical

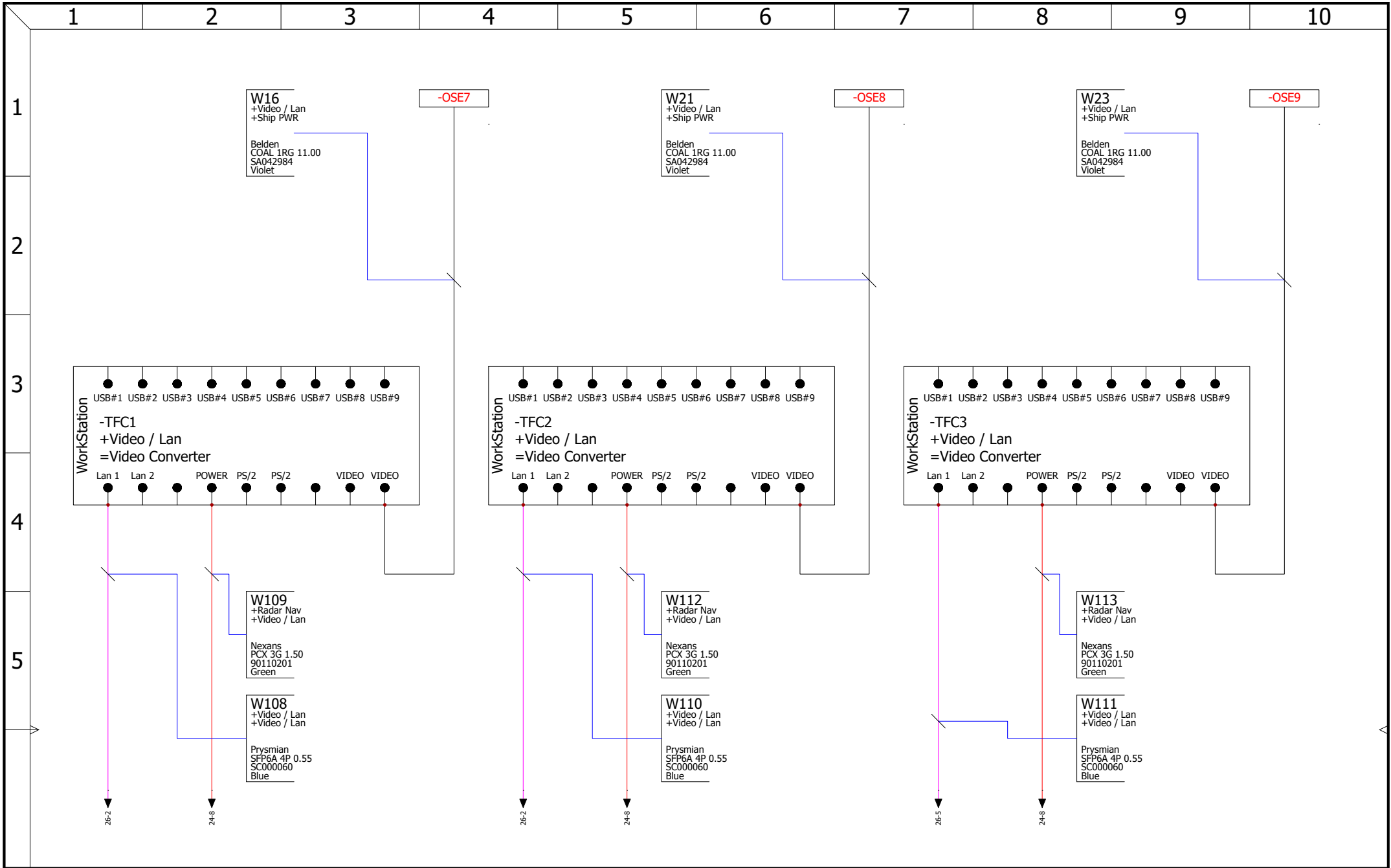

F.C. MARCHINI

HPx-346

CONTRACT:		LOCATION: +TBD		REV. 0		DATE 27/09/2023		NAME F. Marchini		REVISION 0	
				User data 1		User data 2		CHANGES		SCHEME 27	

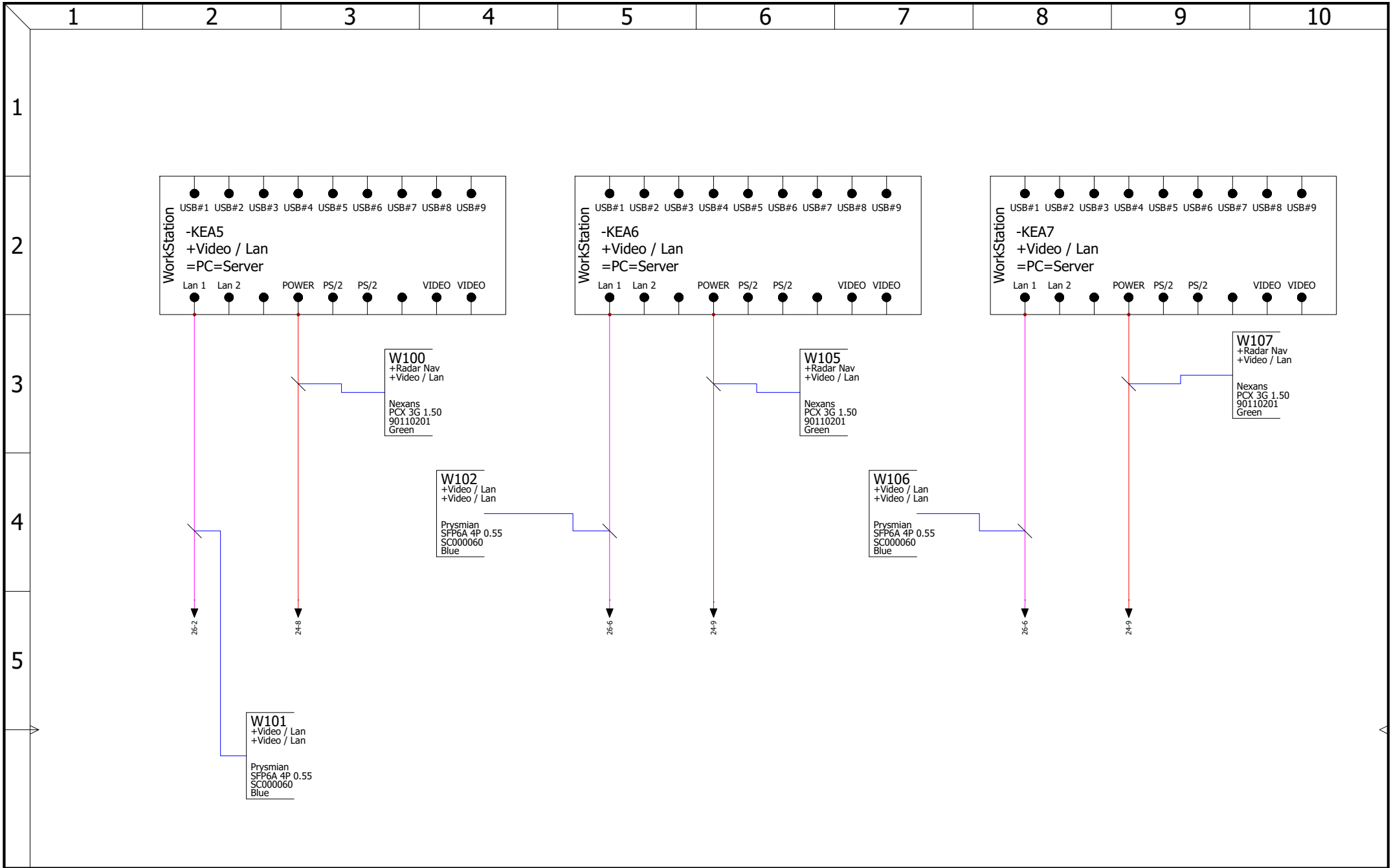

F.C. MARCHINI

RADAR SERVER

CONTRACT:	LOCATION: +TBD				REVISION
					0
		0	27/09/2023	F. Marchini	
		REV.	DATE	NAME	CHANGES
		User data 1	User data 2	SCHEME	28

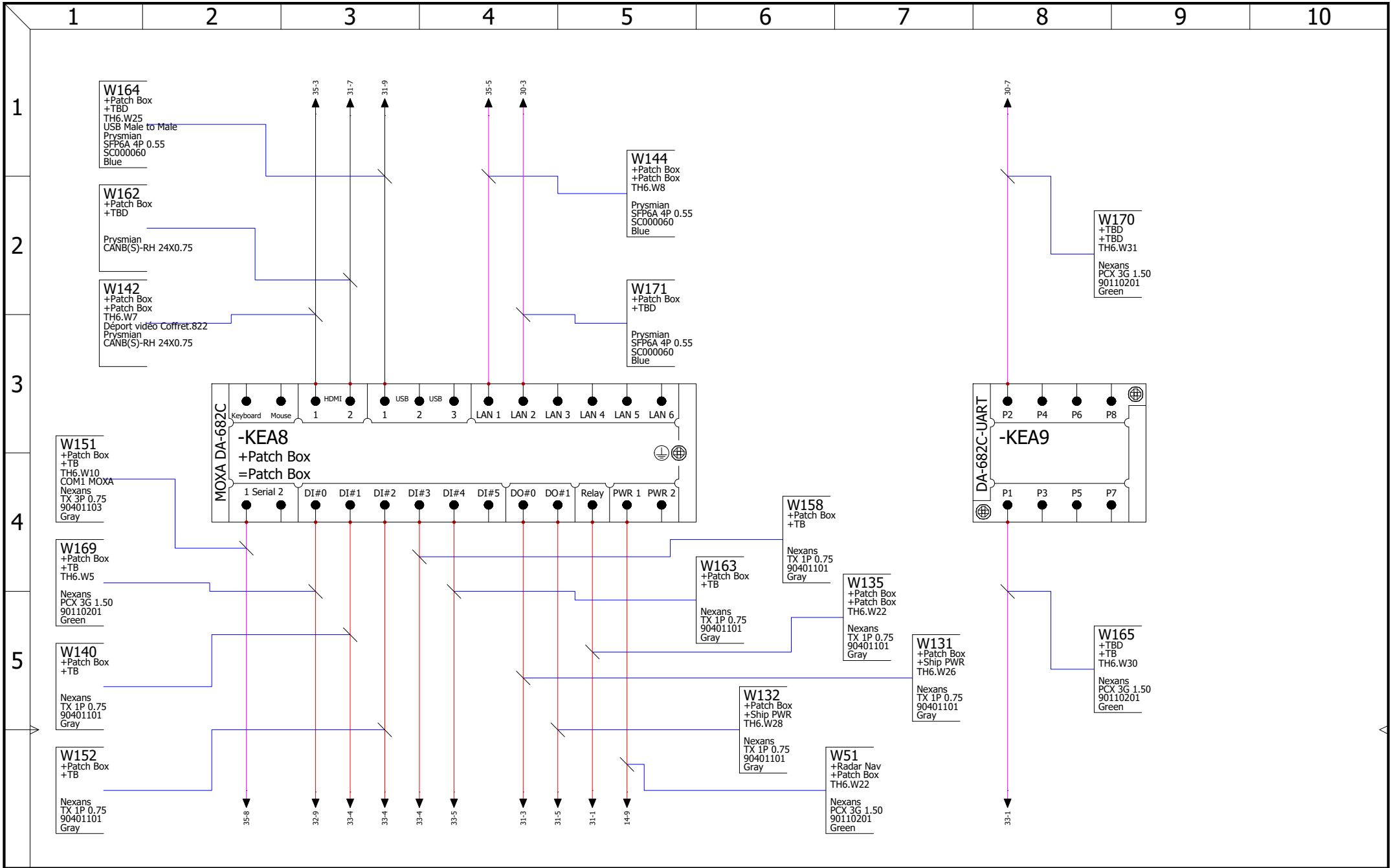

F.C. MARCHINI

Patch Box

CONTRACT:

LOCATION: +TBD

				REVISION
				0
0	15/09/2023	F. Marchini		
REV.	DATE	NAME	CHANGES	
User data 1			User data 2	
				SCHEME
				29

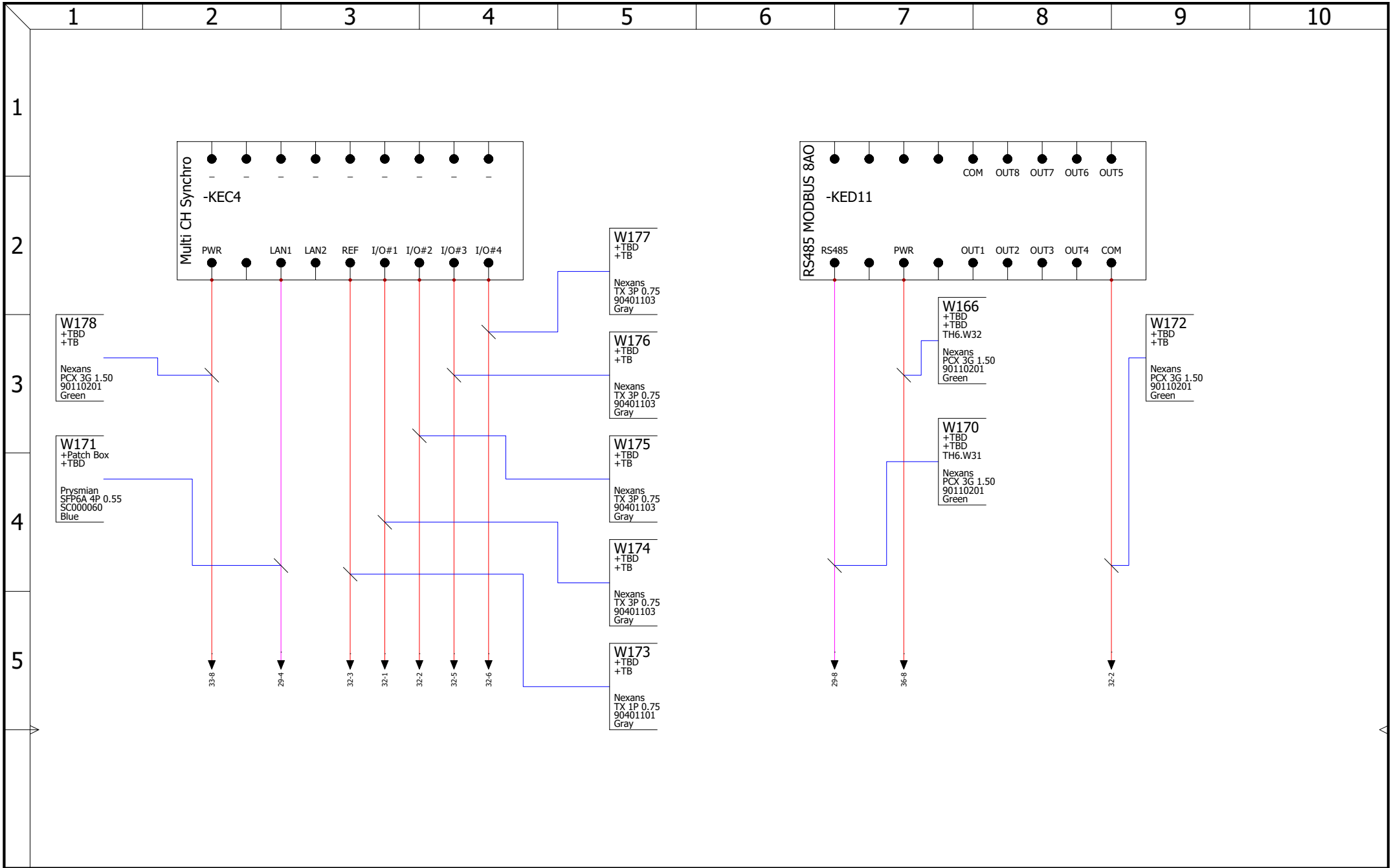

F.C. MARCHINI

Multi Ch & ModBus

CONTRACT:	LOCATION: +TBD	REV.	DATE	NAME	CHANGES	REVISION
		0	30/09/2023	F. Marchini		0
		User data 1				User data 2
						30

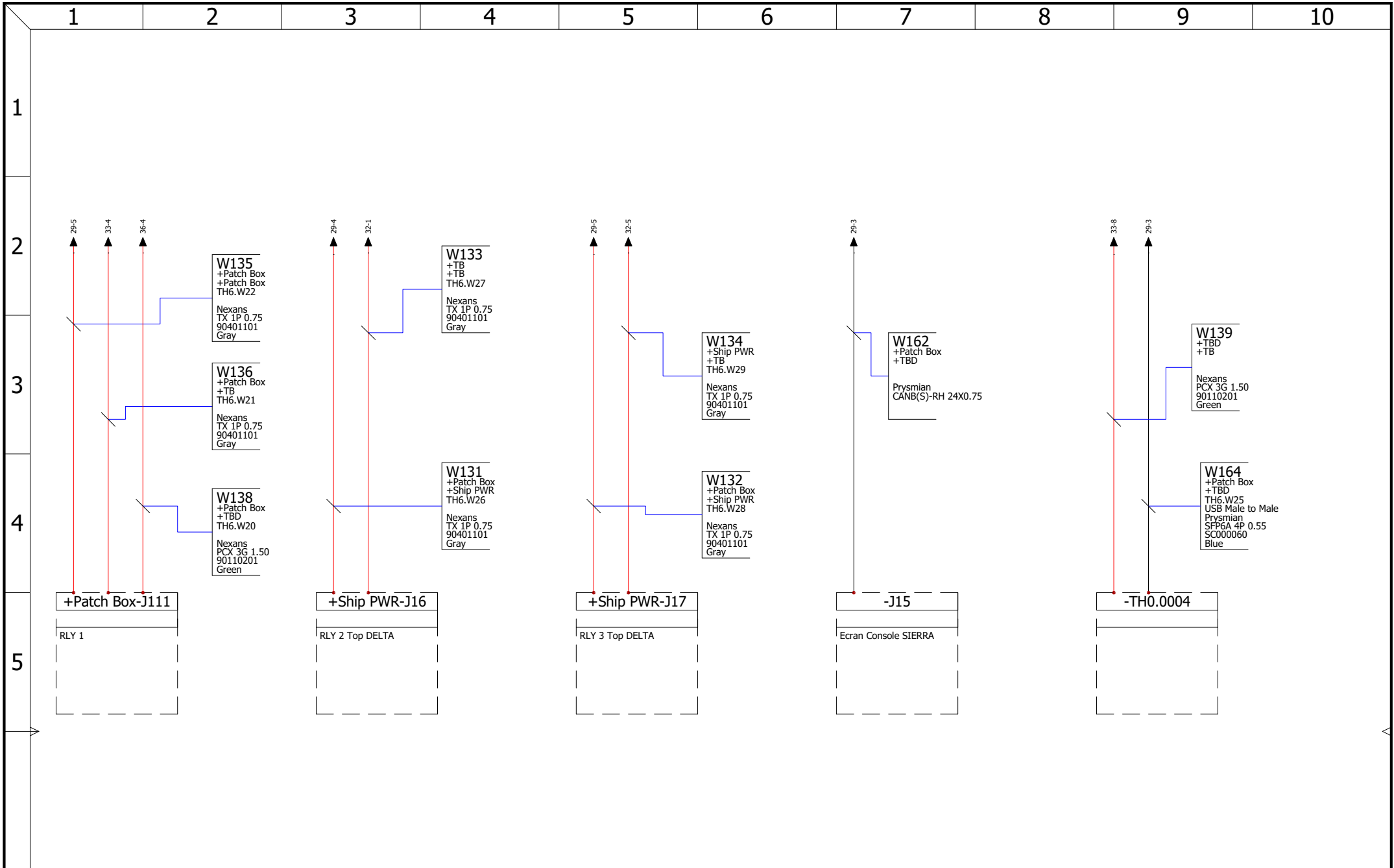

F.C. MARCHINI

Relays #1,#2,#3

CONTRACT:

LOCATION: +TBD

				REVISION
				0
0	29/09/2023	F. Marchini		
REV.	DATE	NAME	CHANGES	SCHEME
User data 1			User data 2	31

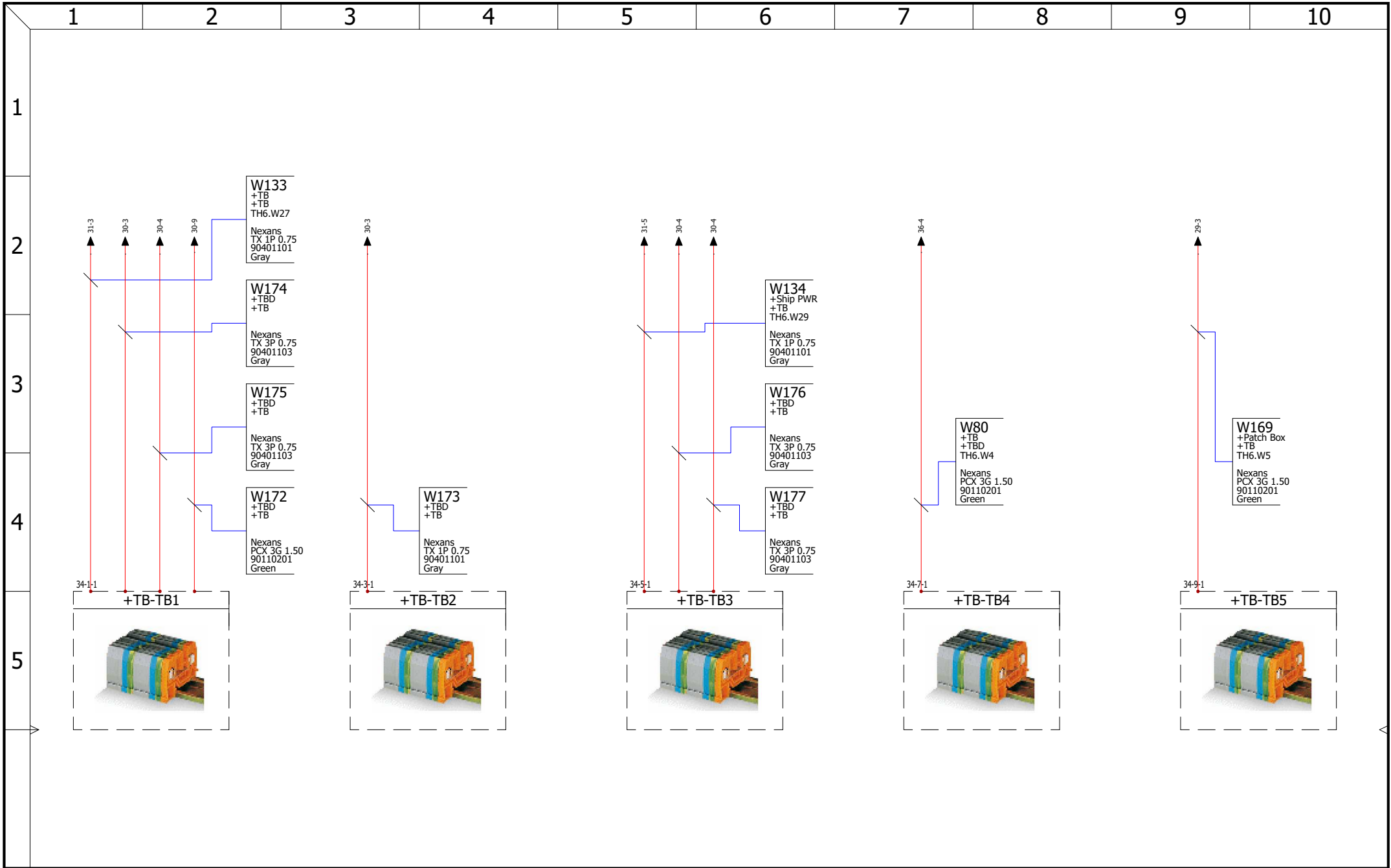

F.C. MARCHINI

TB 1-5

CONTRACT:

LOCATION: +TBD

				REVISION
				0
0	29/09/2023	F. Marchini		
REV.	DATE	NAME	CHANGES	SCHEME
User data 1			User data 2	32

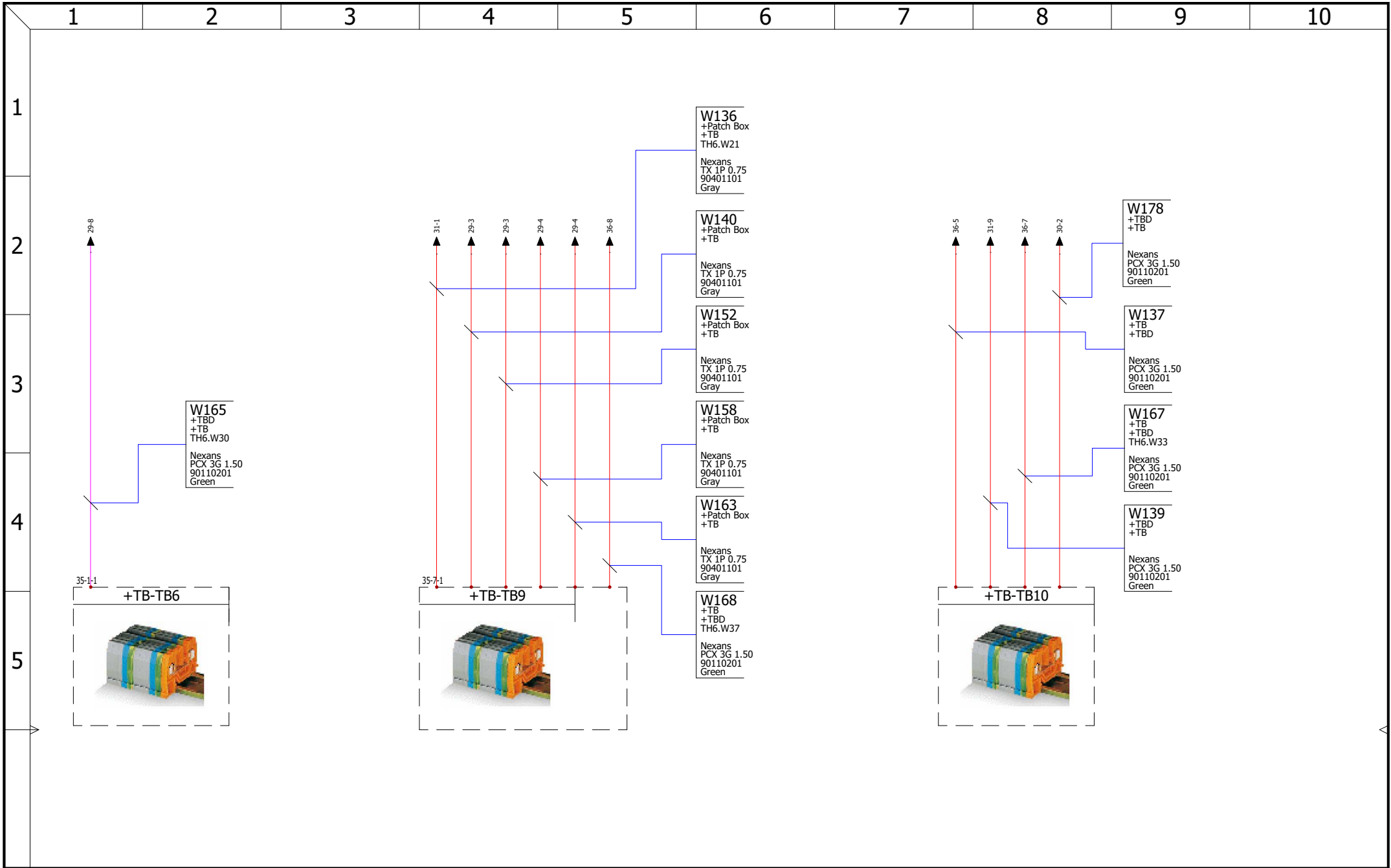

F.C. MARCHINI

TB 6-10

CONTRACT:	LOCATION: +TBD	REV.	DATE	NAME	CHANGES	REVISION
		0	29/09/2023	F. Marchini		0
User data 1					User data 2	SCHEME
						33

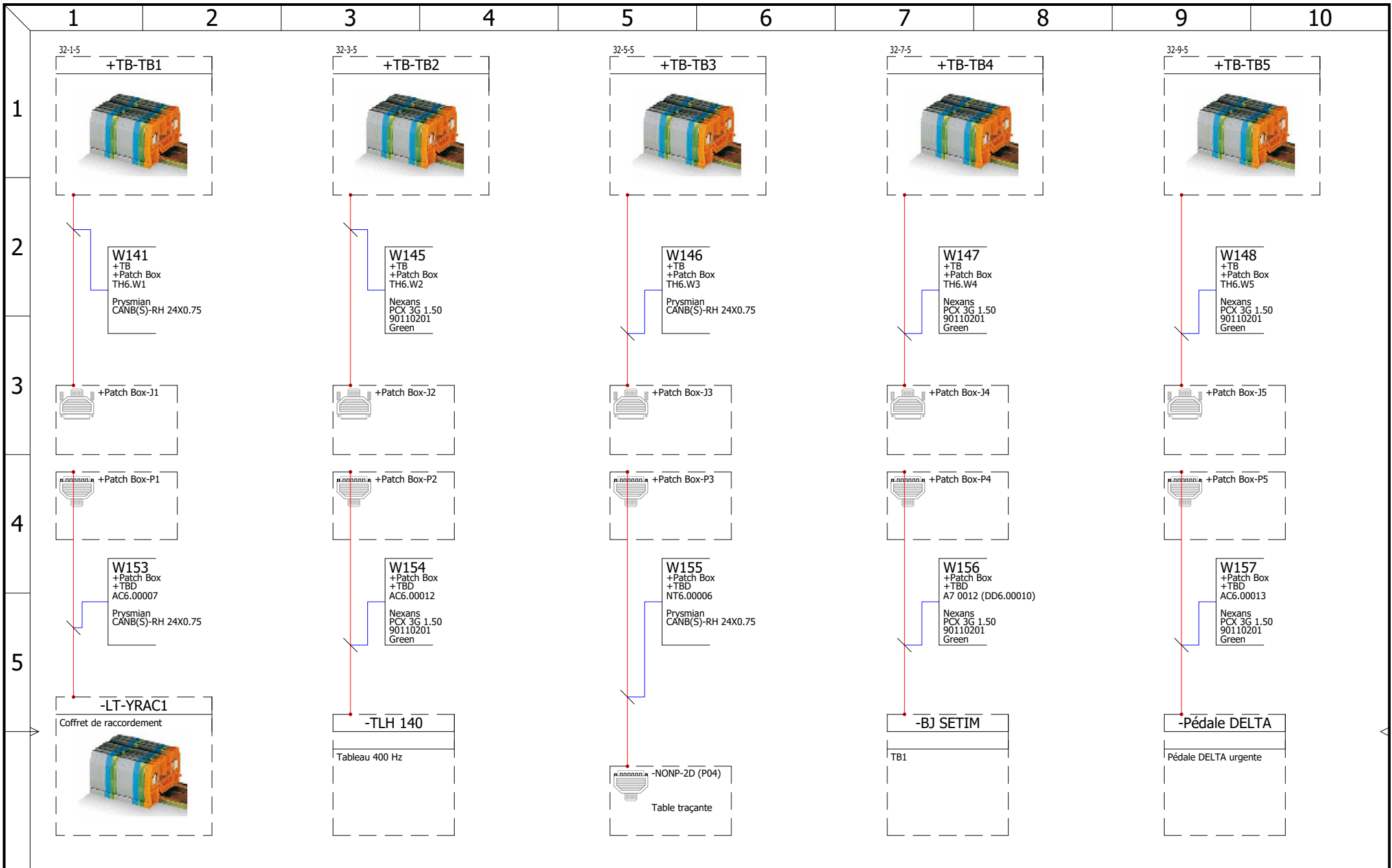

F.C. MARCHINI

Cablage 1-5

CONTRACT:		LOCATION: +TBD		REV. DATE NAME		CHANGES		REVISION
				0	29/09/2023	F. Marchini		0
				User data 1		User data 2		SCHEME
								34

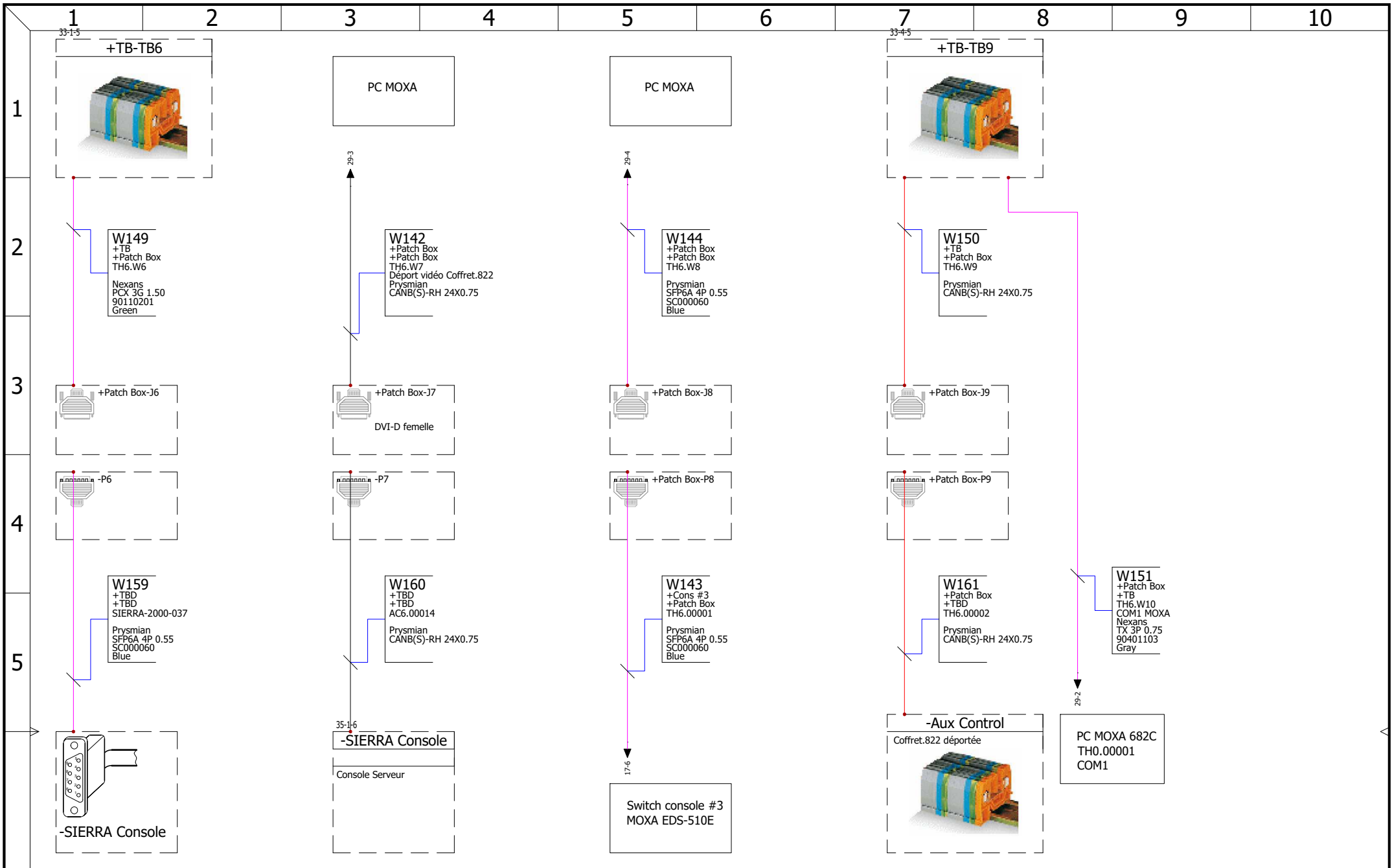

F.C. MARCHINI

Cablage 6-10

CONTRACT:		LOCATION: +TBD		REVISION	
				0	
REV.	DATE	NAME	CHANGES		
	0 29/09/2023	F. Marchini			
User data 1			User data 2		
				SCHEME	
				35	

1 2 3 4 5 6 7 8 9 10

1

2

3

4

5

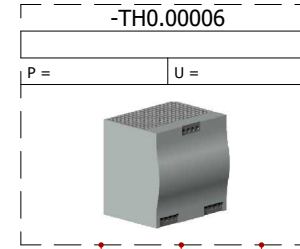
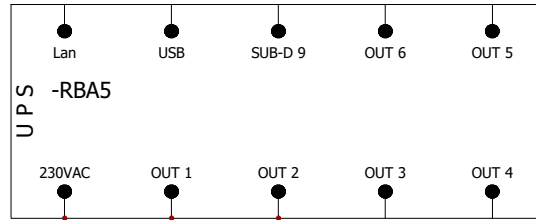

W137
+TB
+TBD
Nexans
PCX 3G 1.50
90110201
Green

W138
+Patch Box
+TBD
TH6.W20
Nexans
PCX 3G 1.50
90110201
Green

W80
+TB
+TBD
TH6.W4
Nexans
PCX 3G 1.50
90110201
Green

W168
+TB
+TBD
TH6.W37
Nexans
PCX 3G 1.50
90110201
Green

W166
+TBD
+TBD
TH6.W32
Nexans
PCX 3G 1.50
90110201
Green

W167
+TB
+TBD
TH6.W33
Nexans
PCX 3G 1.50
90110201
Green

32-7

31-2

33-7

33-8

30-7

33-5

F.C. MARCHINI

Patch Power

				REVISION
				0
0	30/09/2023	F. Marchini		
REV.	DATE	NAME	CHANGES	SCHEME
User data 1			User data 2	36

CONTRACT:

LOCATION: +TBD

-LT-YRAC1

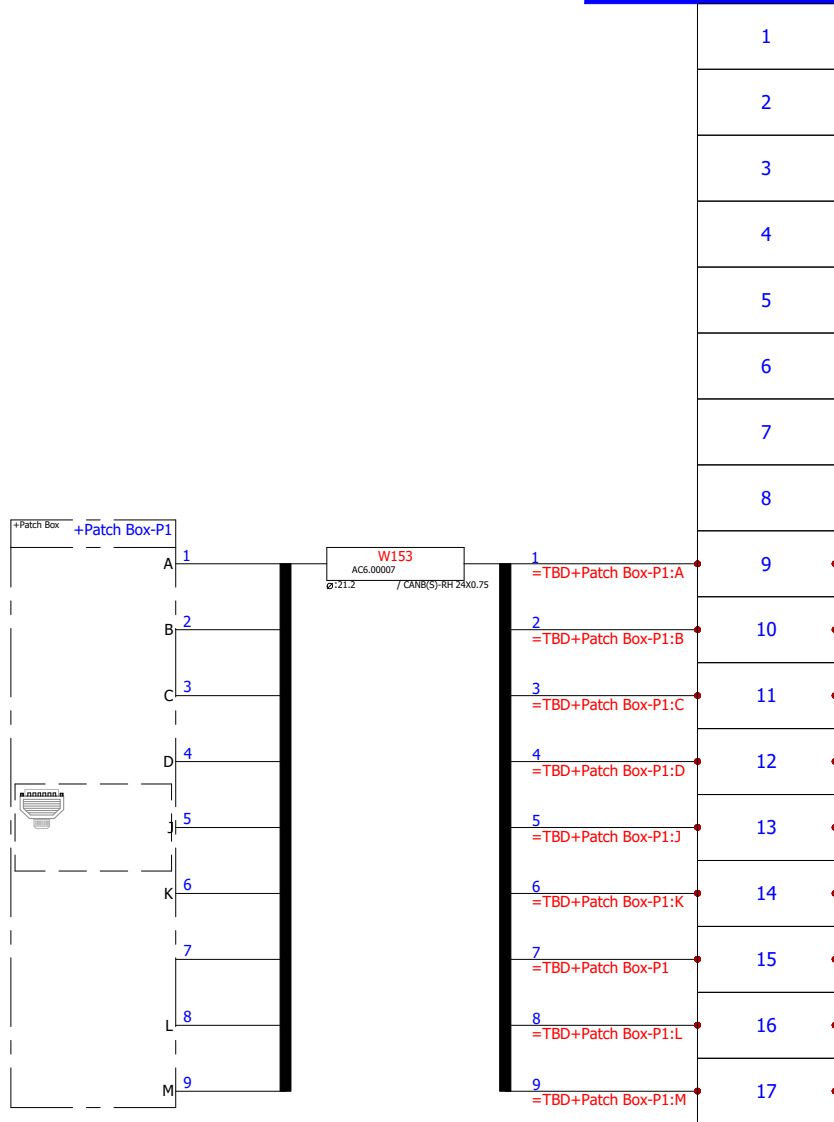

F.C. MARCHINI

Document book

REV.	DATE	NAME	CHANGES	REVISION
0	30/09/2023	F. Marchini		0
				SCHEME
				37

CONTRACT:

LOCATION: +TBD

User data 1

User data 2

-LT-YRAC1

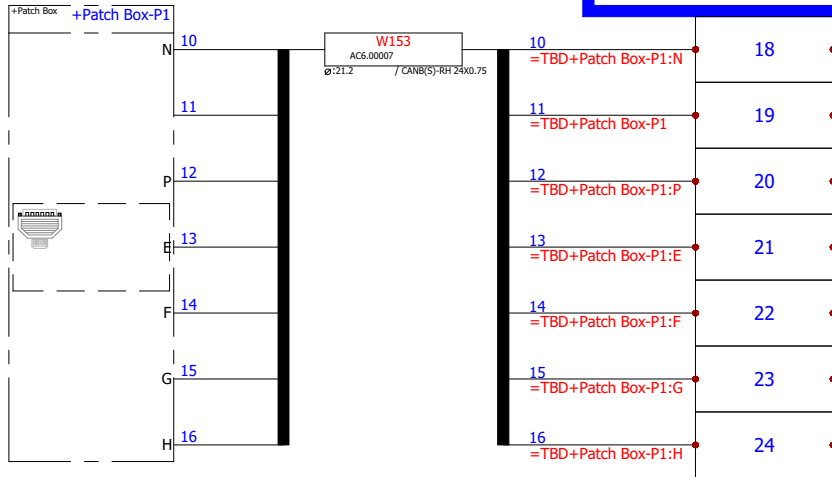

F.C. MARCHINI

Document book

REVISION

0

REV.	DATE	NAME	CHANGES
0	30/09/2023	F. Marchini	
User data 1			User data 2

SCHEME

38

CONTRACT:

LOCATION: +TBD

-Aux Control

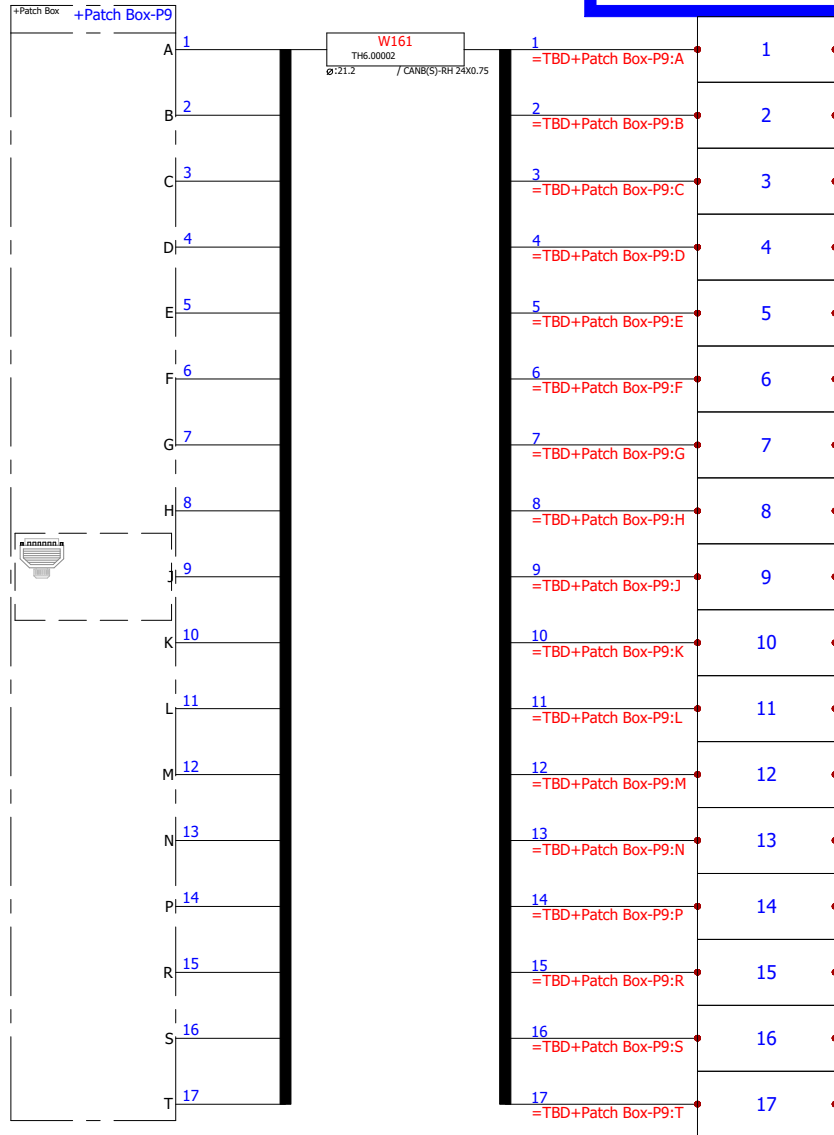

F.C. MARCHINI

Document book

CONTRACT:

LOCATION: +TBD

REV.	DATE	NAME	CHANGES	REVISION
0	30/09/2023	F. Marchini		0
				SCHEME
				39

User data 1

User data 2

-Aux Control

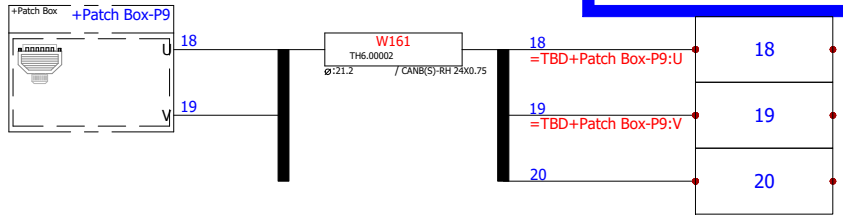

SOLIDWORKS Electrical

F.C. MARCHINI

Document book

					REVISION
					0
0	30/09/2023	F. Marchini			SCHEME
REV.	DATE	NAME	CHANGES		40
User data 1				User data 2	

CONTRACT:

LOCATION: +TBD

-TB1



SOLIDWORKS Electrical

F.C. MARCHINI

Document book

				REVISION
				0
0	30/09/2023	F. Marchini		
REV.	DATE	NAME	CHANGES	SCHEME
				41

CONTRACT:

LOCATION: +TB

User data 1

User data 2

+TB
+TB-TB1

18

19

20

F.C. MARCHINI

Document book

REV.	DATE	NAME	CHANGES	REVISION
0	30/09/2023	F. Marchini		0
				SCHEME
				42

CONTRACT:

LOCATION: +TBD

User data 1

User data 2

-TB2

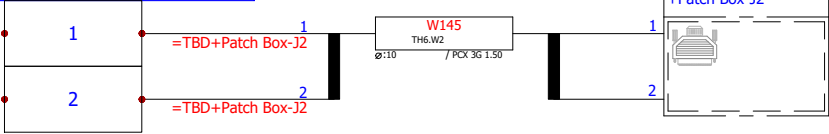

SOLIDWORKS Electrical

F.C. MARCHINI

Document book

				REVISION
				0
0	30/09/2023	F. Marchini		
REV.	DATE	NAME	CHANGES	SCHEME
				43

CONTRACT:

LOCATION: +TB

User data 1

User data 2

-TB3

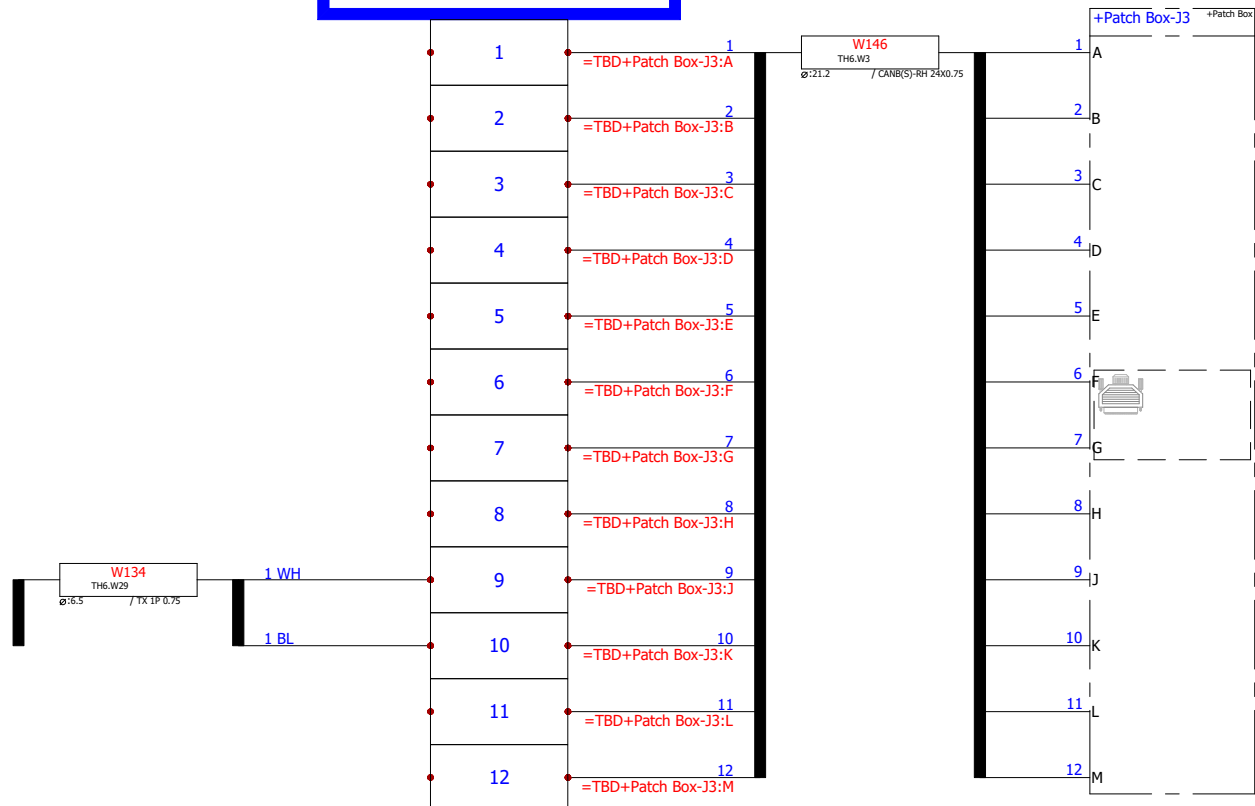

F.C. MARCHINI

Document book

				REVISION
				0
0	30/09/2023	F. Marchini		
REV.	DATE	NAME	CHANGES	SCHEME
				44

CONTRACT:

LOCATION: +TB

User data 1

User data 2

-TB4

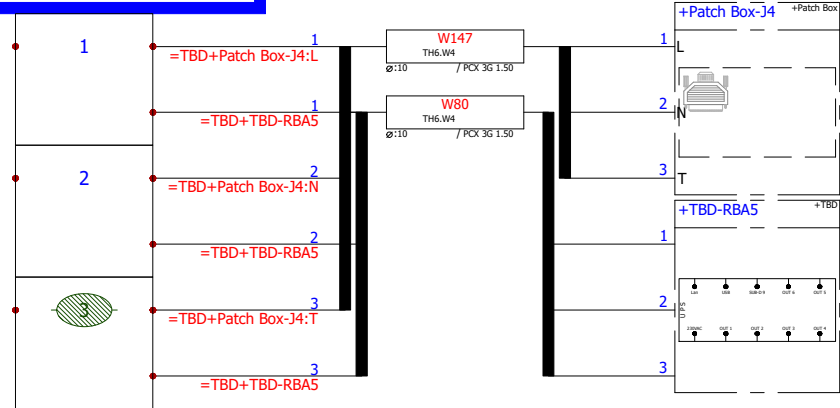

F.C. MARCHINI

Document book

REVISION

0

0 30/09/2023 F. Marchini

REV.	DATE	NAME	CHANGES
0	30/09/2023	F. Marchini	

SCHEME

45

CONTRACT:

LOCATION: +TB

User data 1

User data 2

-TB5

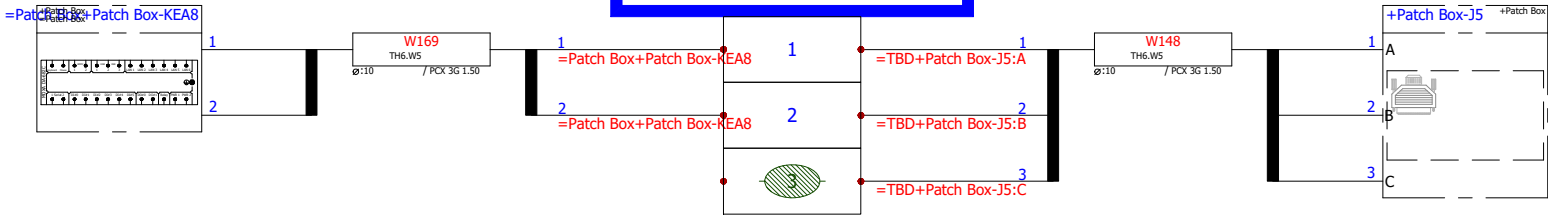

SOLIDWORKS Electrical

F.C. MARCHINI

Document book

REVISION	0
SCHEME	46

REV.	DATE	NAME	CHANGES
0	30/09/2023	F. Marchini	
User data 1			User data 2

CONTRACT:

LOCATION: +TB

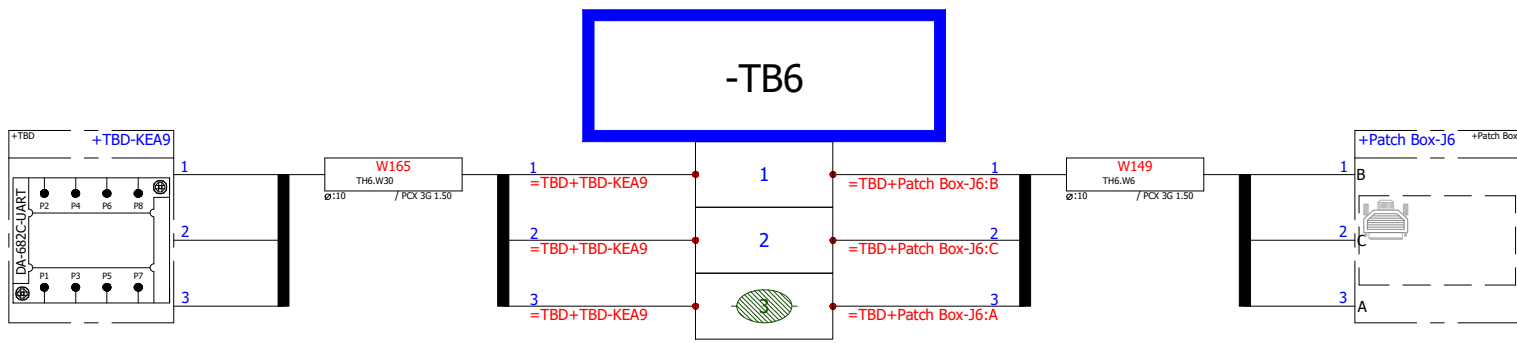

F.C. MARCHINI

Document book

CONTRACT:

LOCATION: +TB

				REVISION
				0
0	30/09/2023	F. Marchini		
REV.	DATE	NAME	CHANGES	SCHEME
				47
User data 1			User data 2	

-TB9

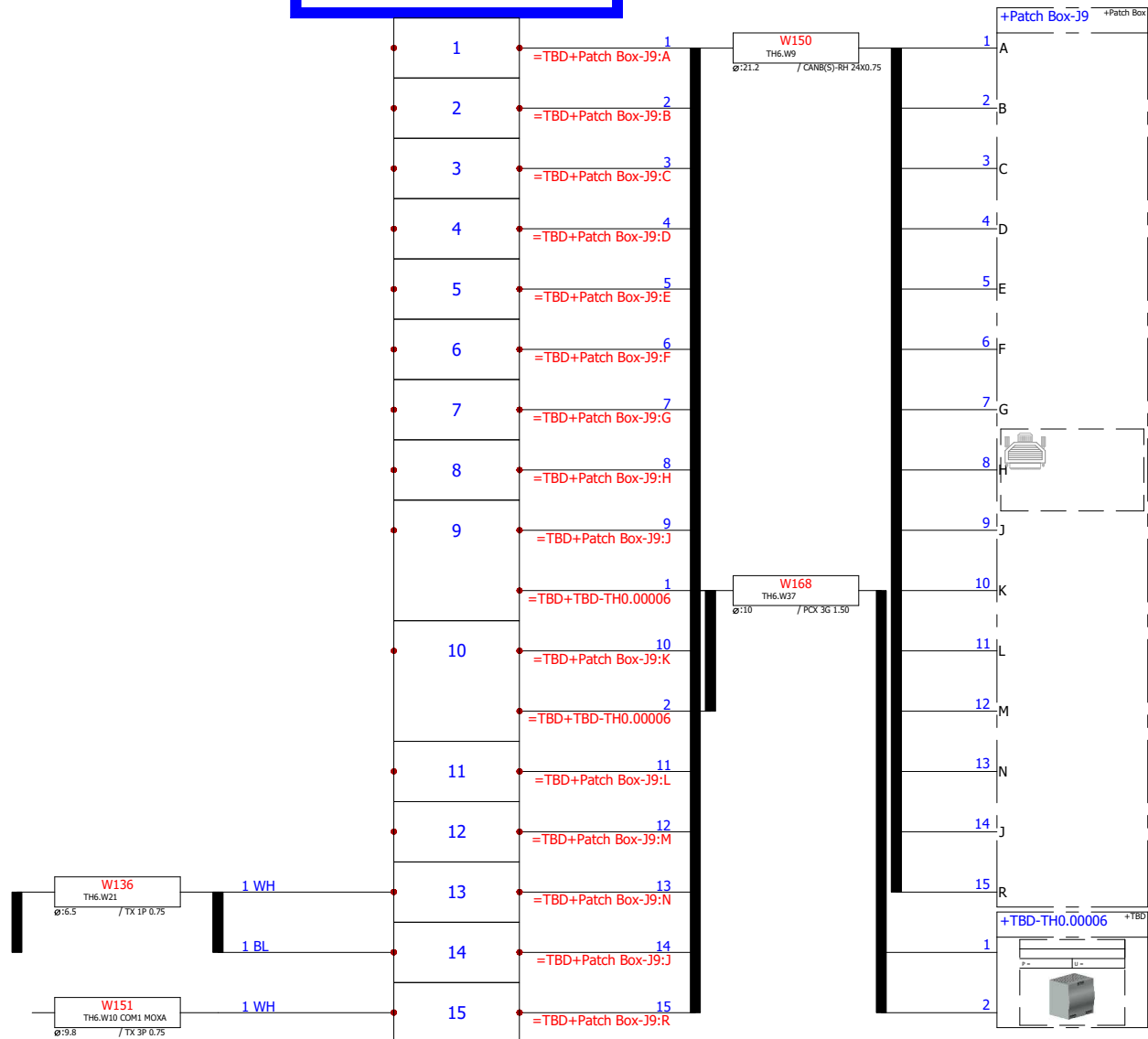

F.C. MARCHINI

Document book

REVISION

0

0	30/09/2023	F. Marchini	
REV.	DATE	NAME	CHANGES
User data 1			User data 2

SCHEME

48

CONTRACT:

LOCATION: +TB

-TB9

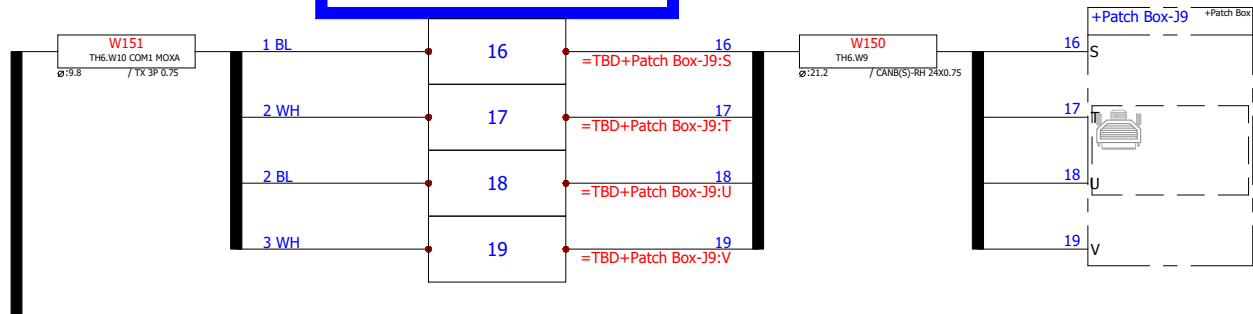

F.C. MARCHINI

Document book

				REVISION
				0
0	30/09/2023	F. Marchini		
REV.	DATE	NAME	CHANGES	SCHEME
			User data 1	49
			User data 2	

CONTRACT:

LOCATION: +TB

-TB10

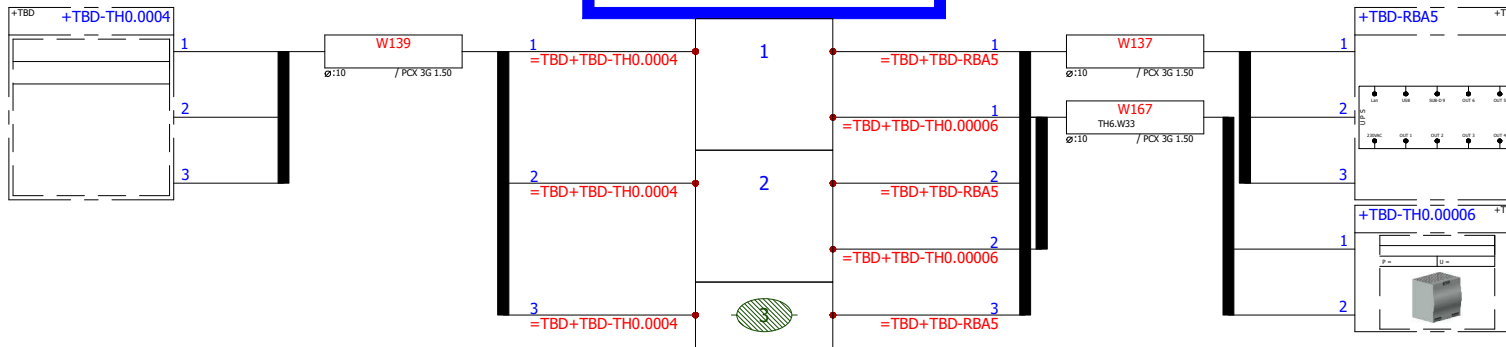

F.C. MARCHINI

Document book

REVISION

0

0	30/09/2023	F. Marchini
---	------------	-------------

REV.	DATE	NAME	CHANGES

SCHEME

50

CONTRACT:

LOCATION: +TB

User data 1

User data 2